

# Perfect Pocket Door Set - Installation Instruction

1-1 FG

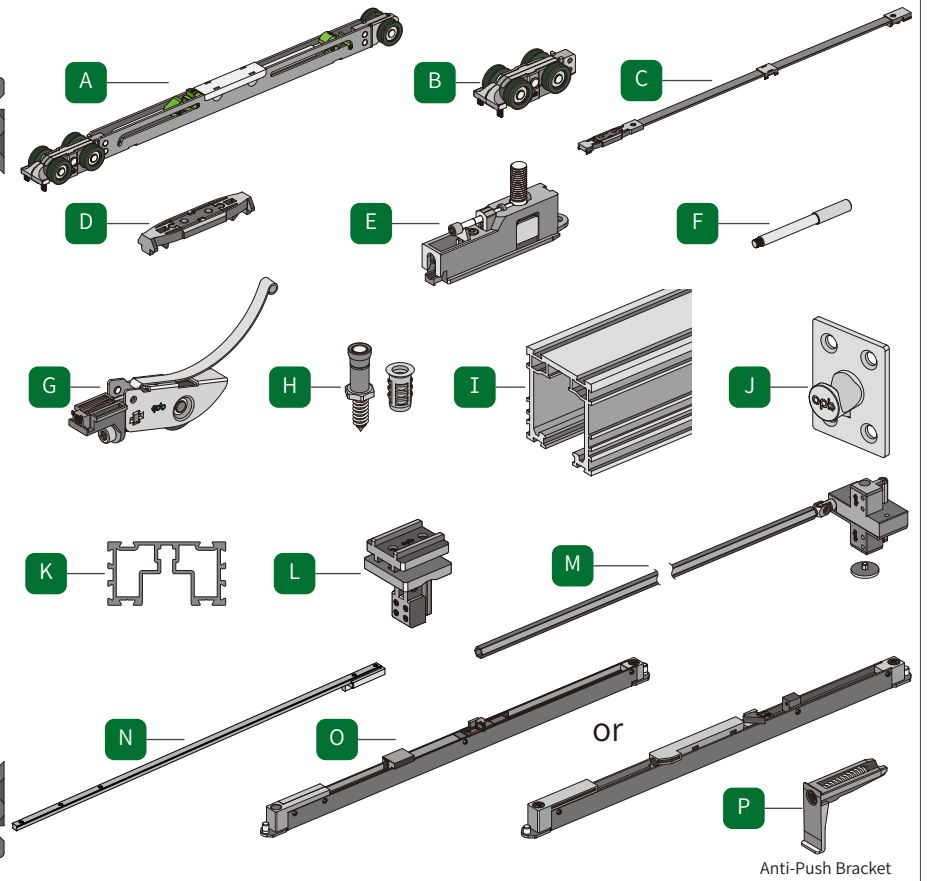

1-2 FD

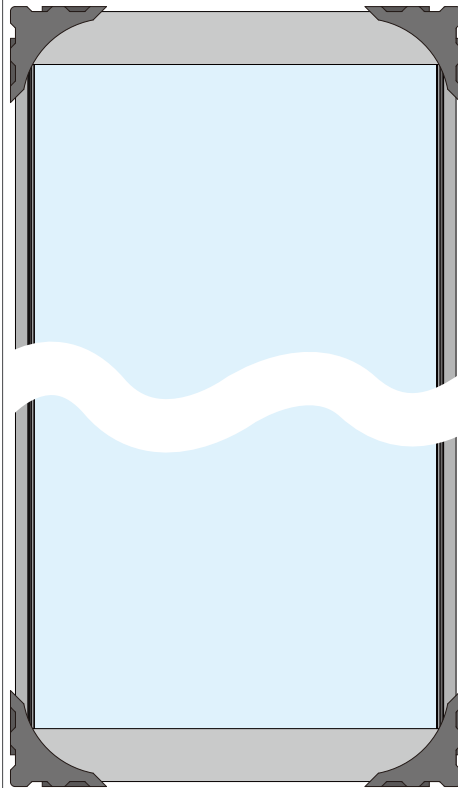
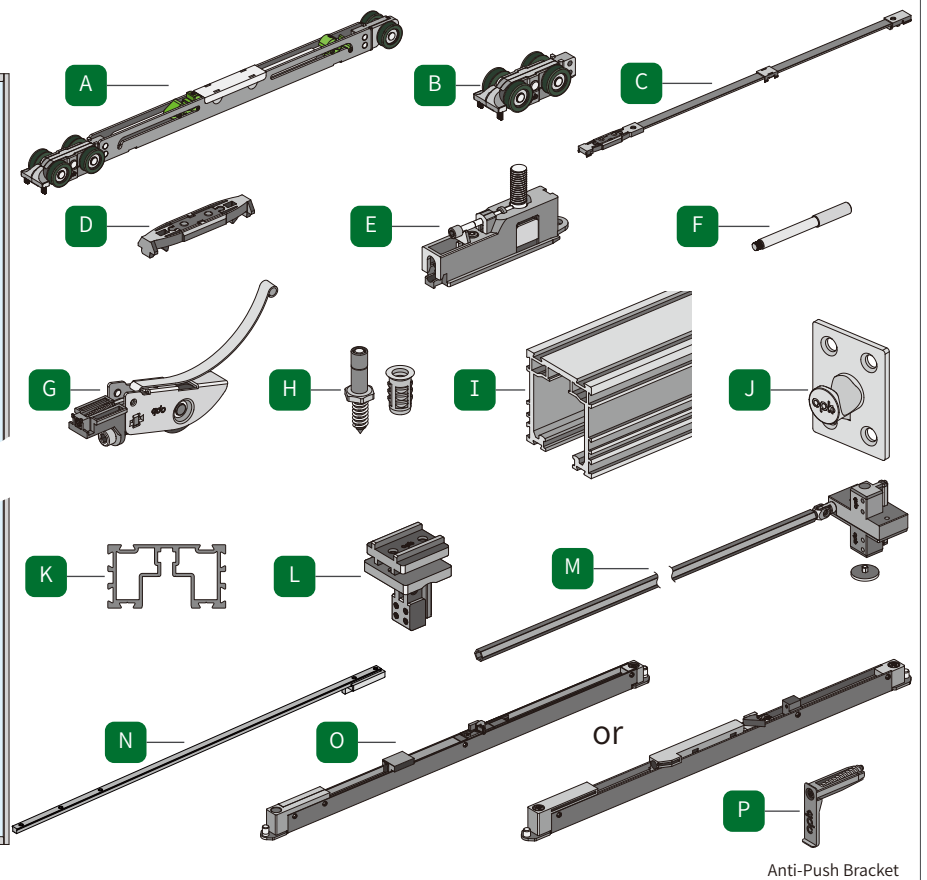
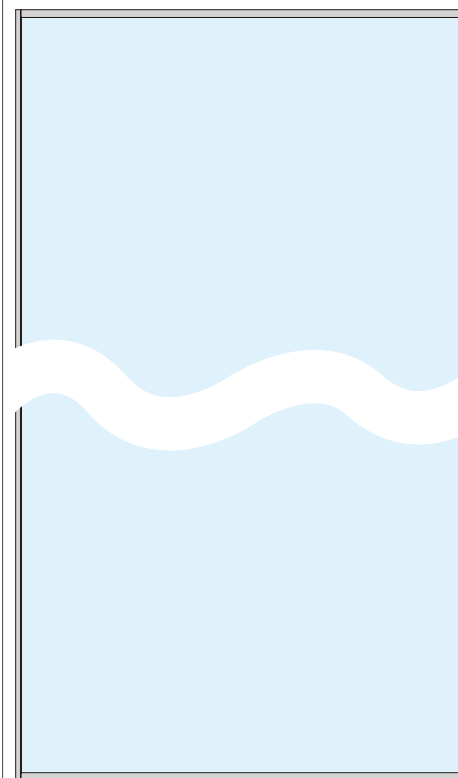

1-3 FW

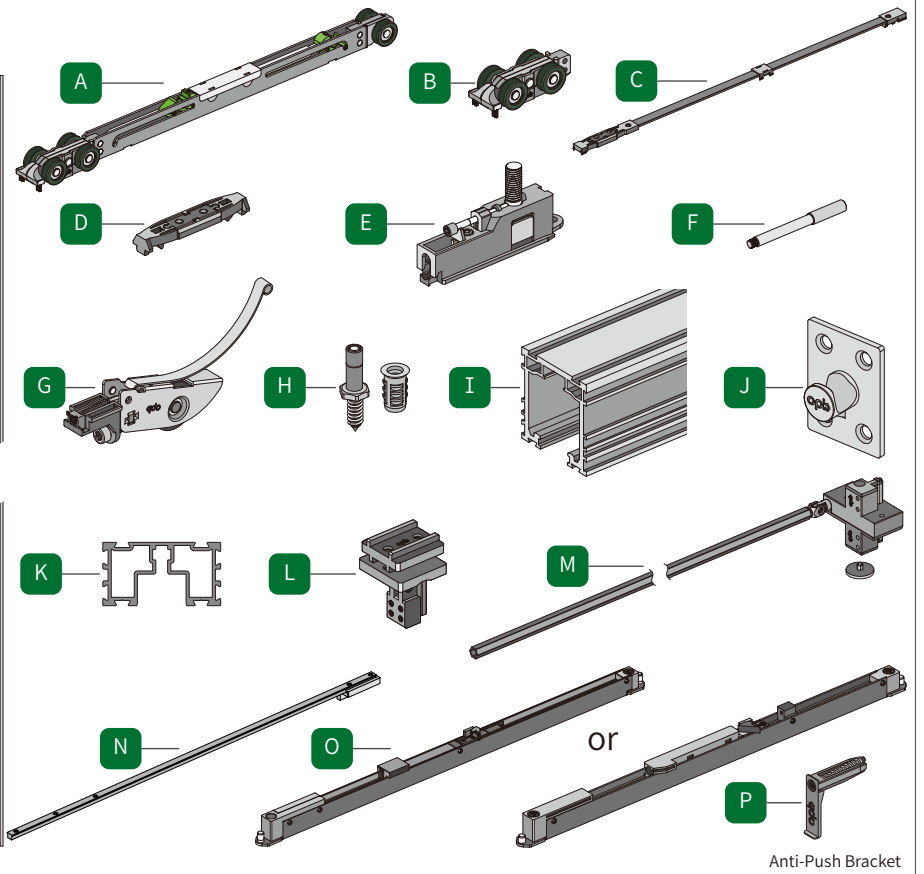
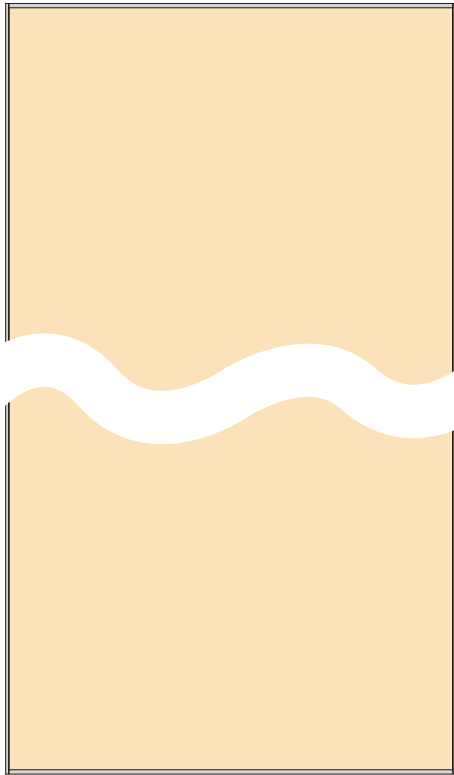

1-4 W

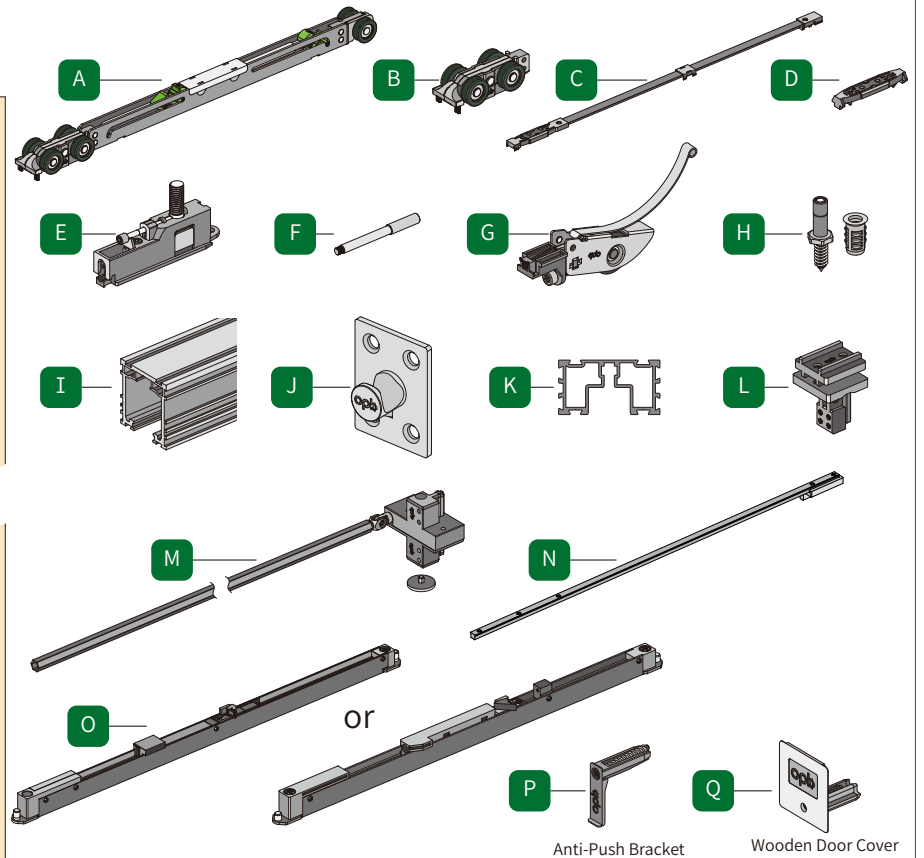
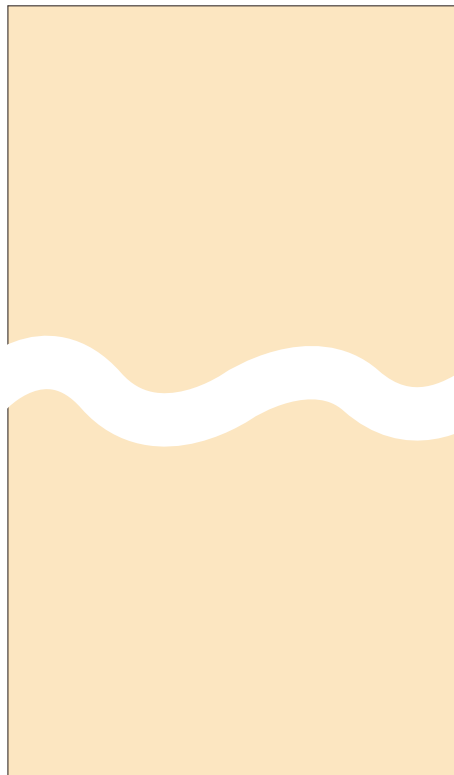

Install Wooden Door Cover: Pages 23

2-1 Surface Mounting FG

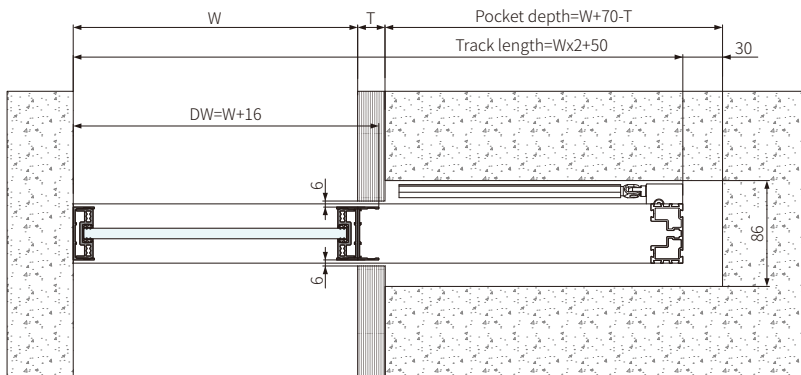
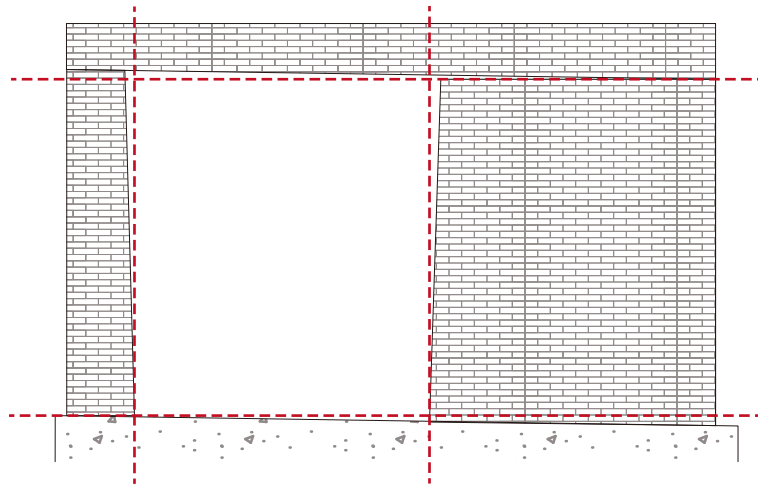
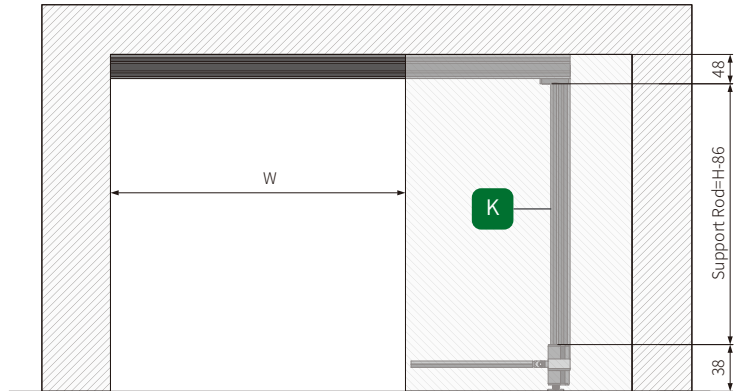
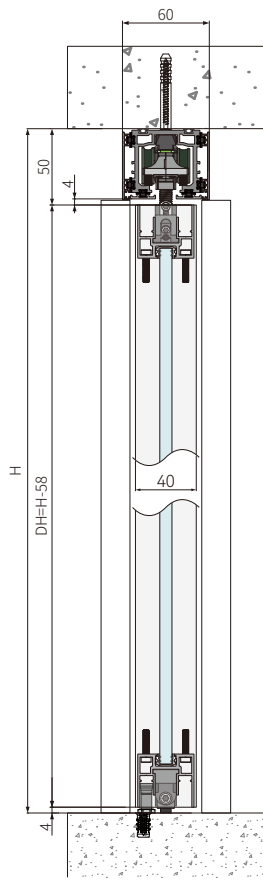

H: Door opening height  
 DH: Door height  
 W: Door opening width  
 DW: Door width  
 T: Trim thickness

2-2 Concealed Mounting FG

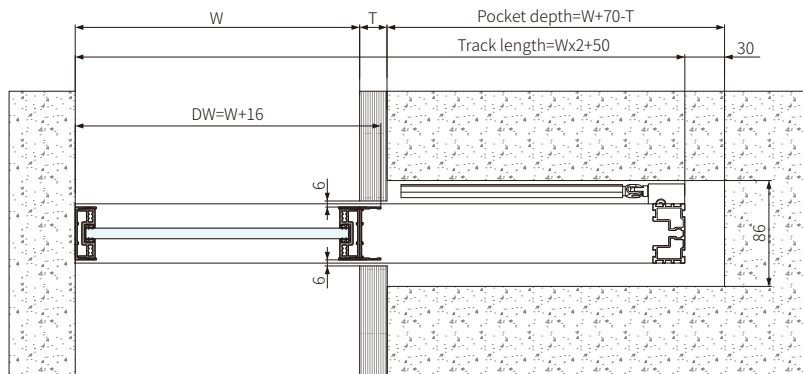
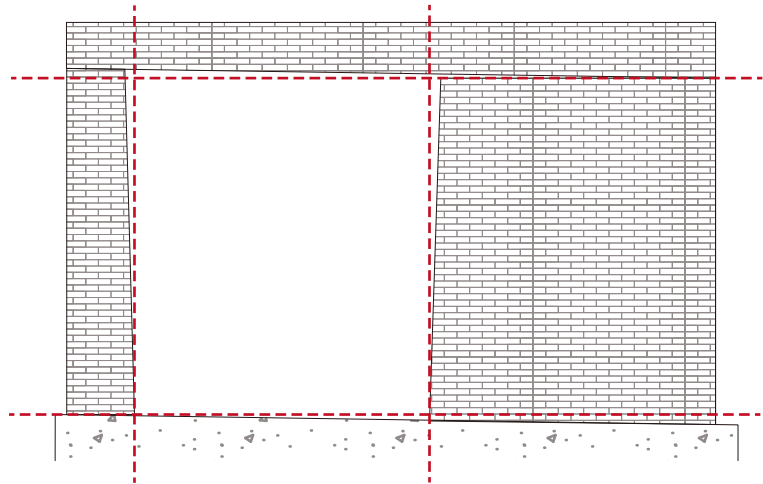
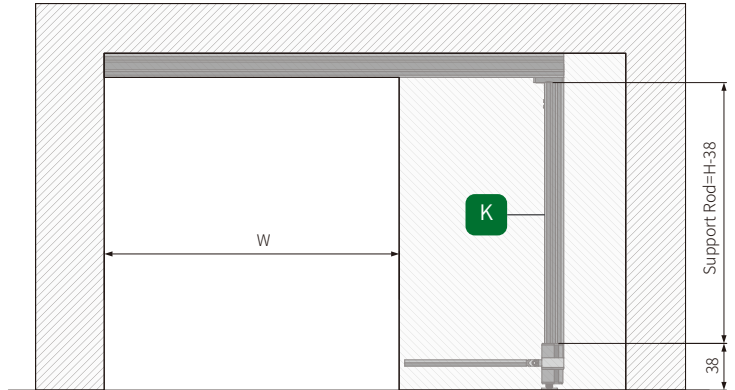
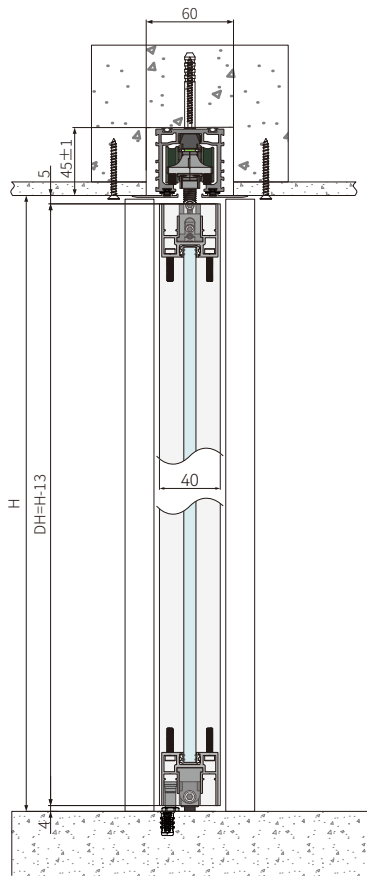

H: Door opening height  
 DH: Door height  
 W: Door opening width  
 DW: Door width  
 T: Trim thickness

2-3 Surface Mounting FW

	Door Thickness
FW	46.5
FD	46.5

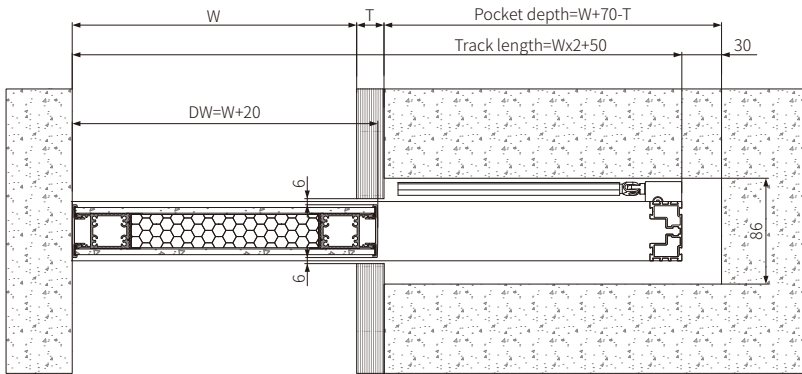
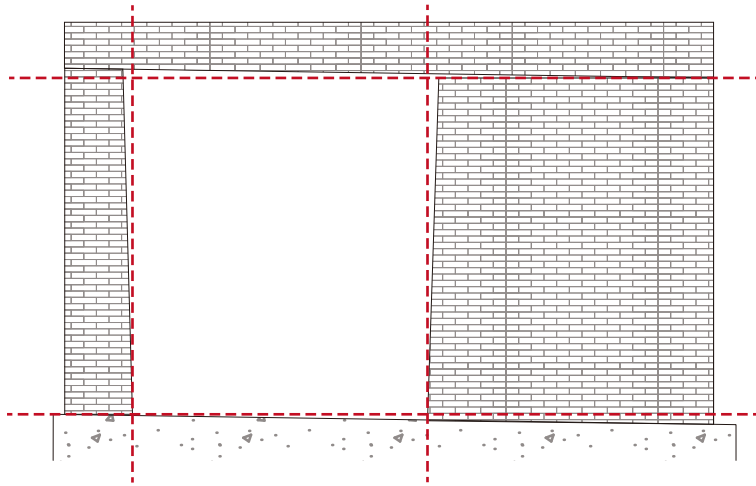
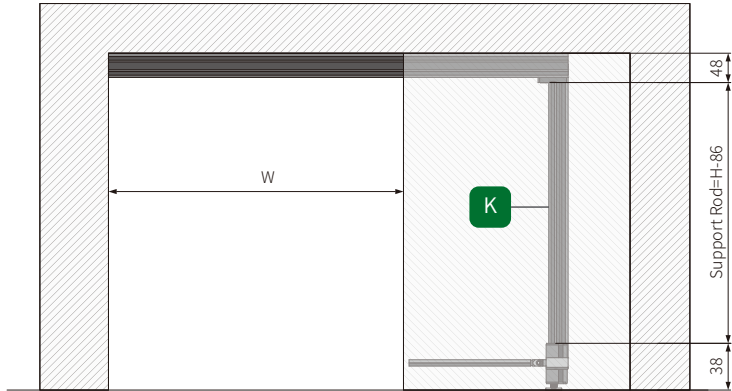
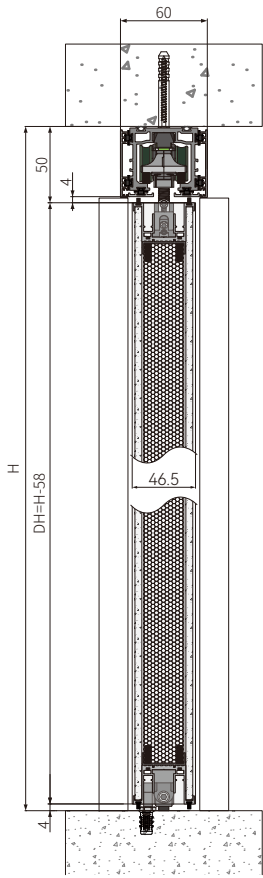

H: Door opening height  
 DH: Door height  
 W: Door opening width  
 DW: Door width  
 T: Trim thickness

2-4 Concealed Mounting FW

	Door Thickness
FW	46.5
FD	46.5

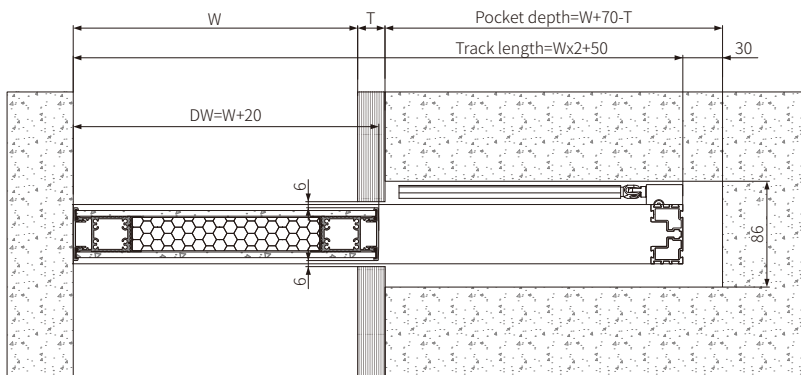
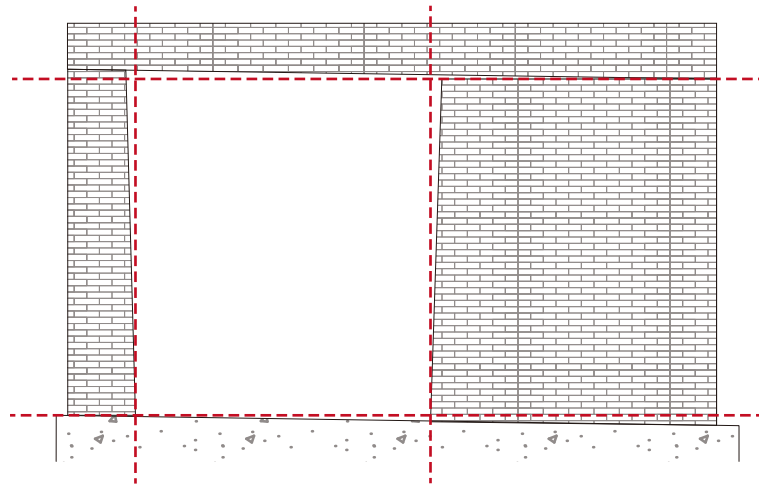
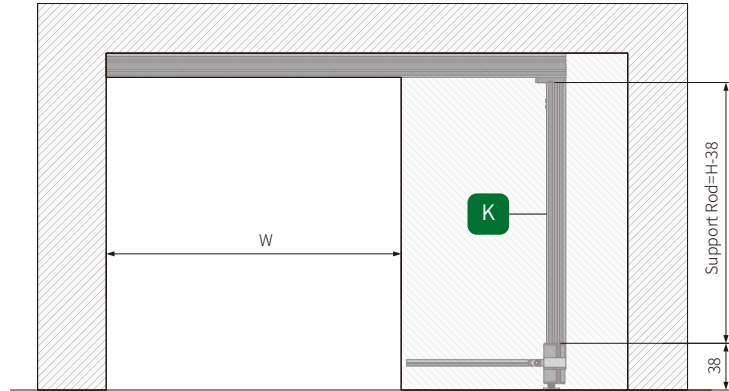
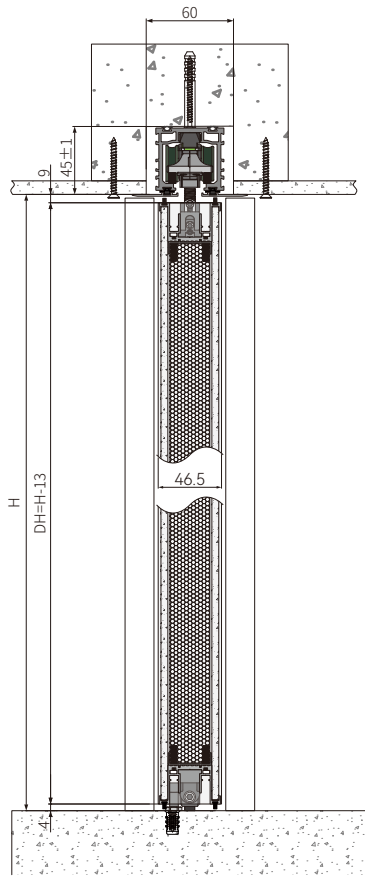

H: Door opening height  
 DH: Door height  
 W: Door opening width  
 DW: Door width  
 T: Trim thickness

2-5 Surface Mounting W

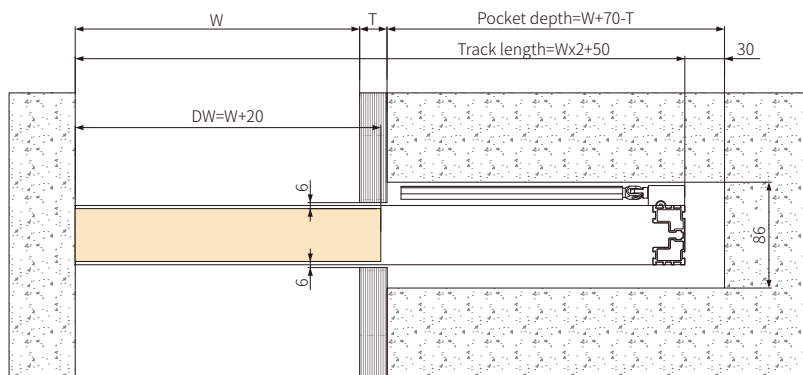
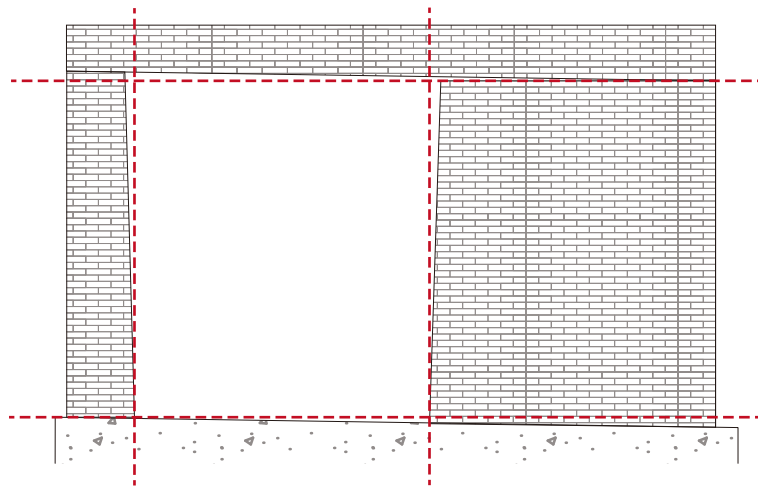
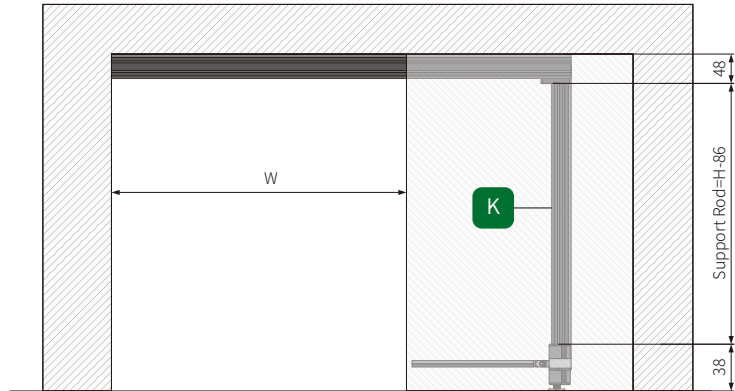
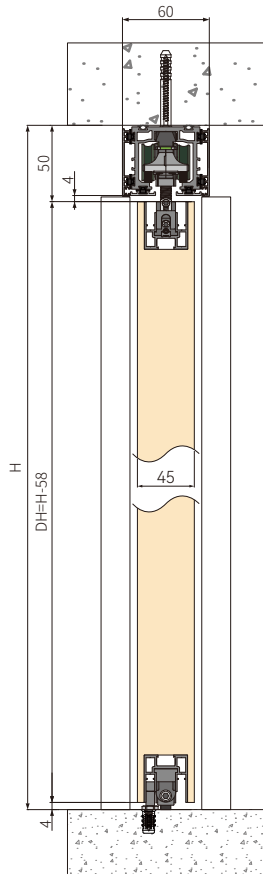

H: Door opening height  
 DH: Door height  
 W: Door opening width  
 DW: Door width  
 T: Trim thickness

2-6 Concealed Mounting W

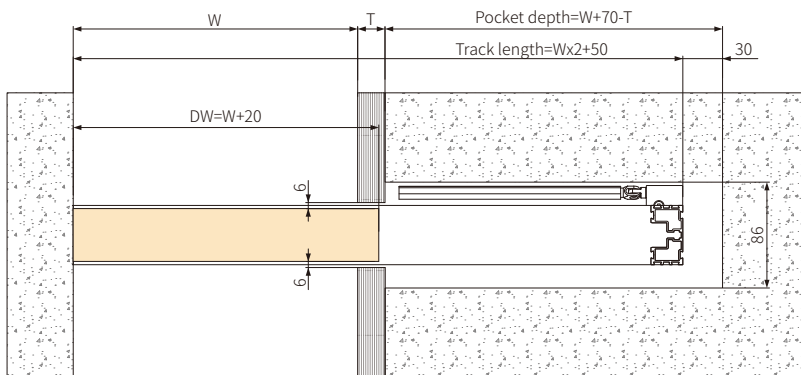
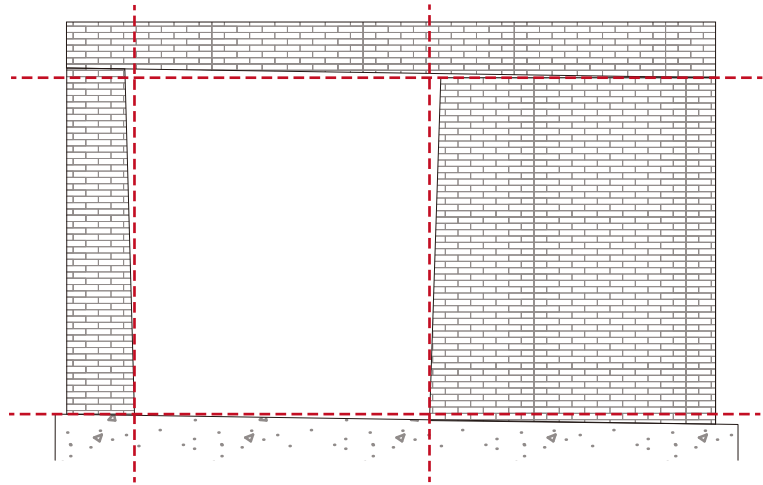
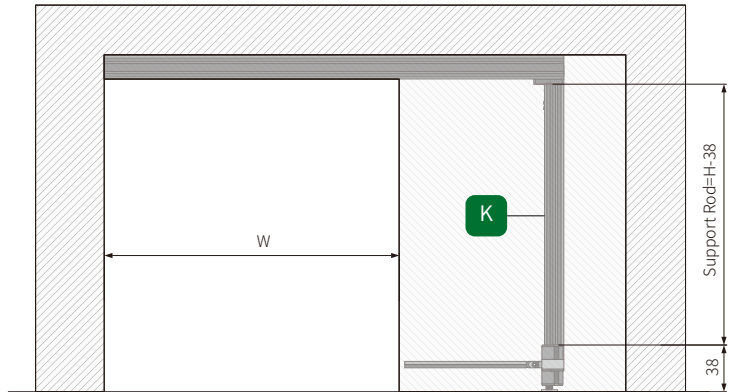
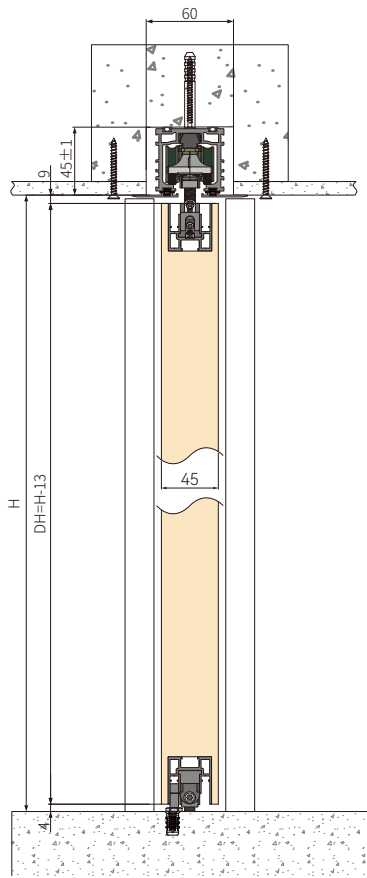

H: Door opening height  
 DH: Door height  
 W: Door opening width  
 DW: Door width  
 T: Trim thickness

Processing Parameters

Track

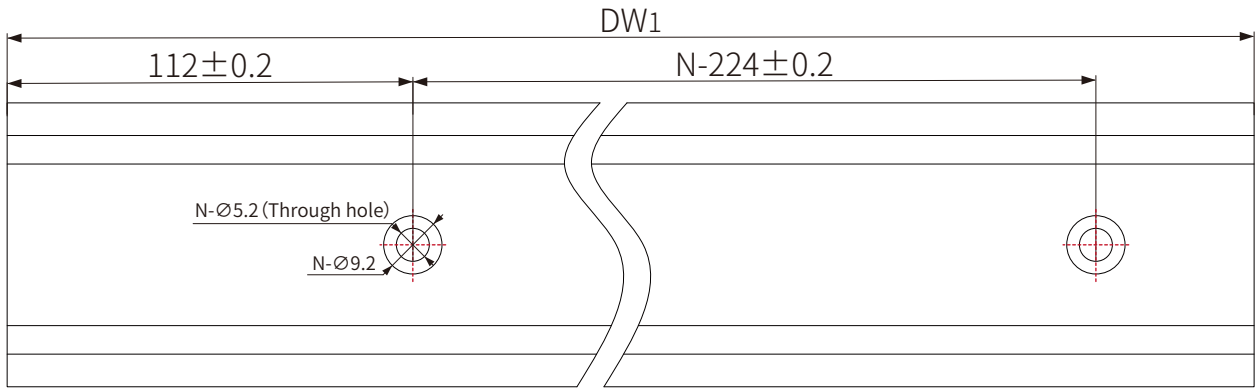
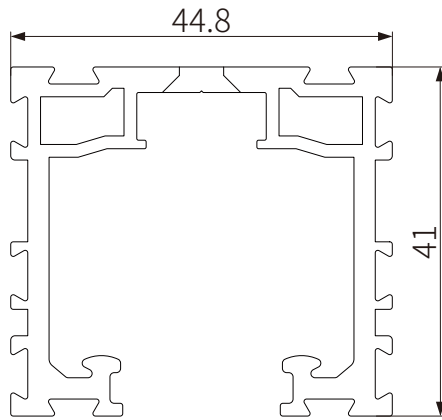

Vertical Cover

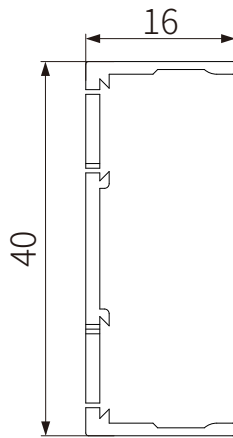

 Cut to proper length before any processing

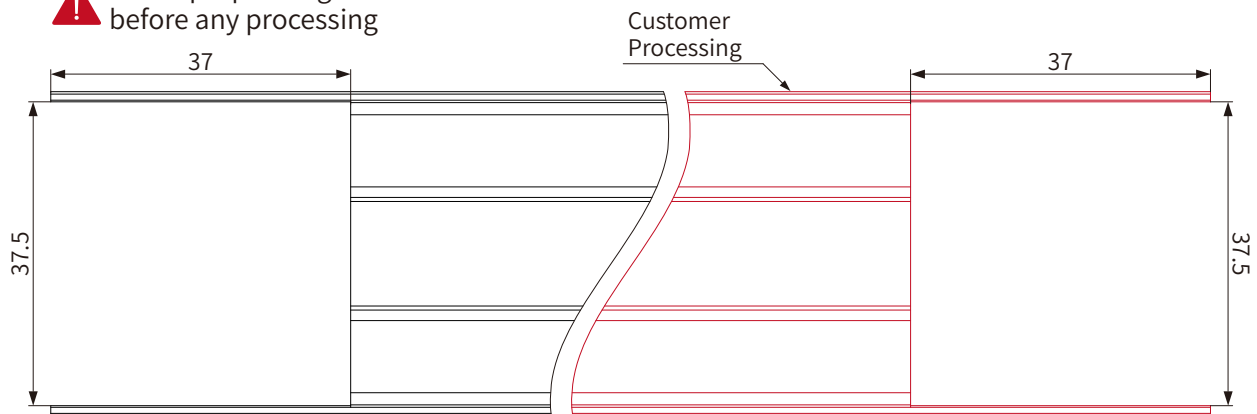

### 3-1 Install the Door FG

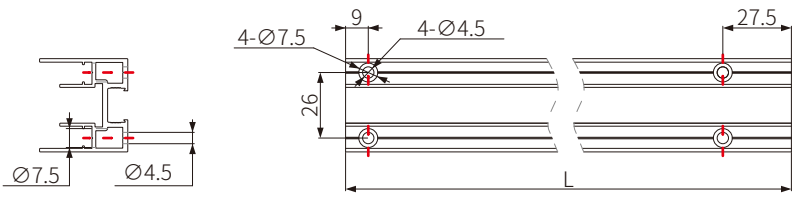

Note: Use an OPK professional punching machine or CNC processing

⚠ Please refer to the door panel production manual for detailed installation

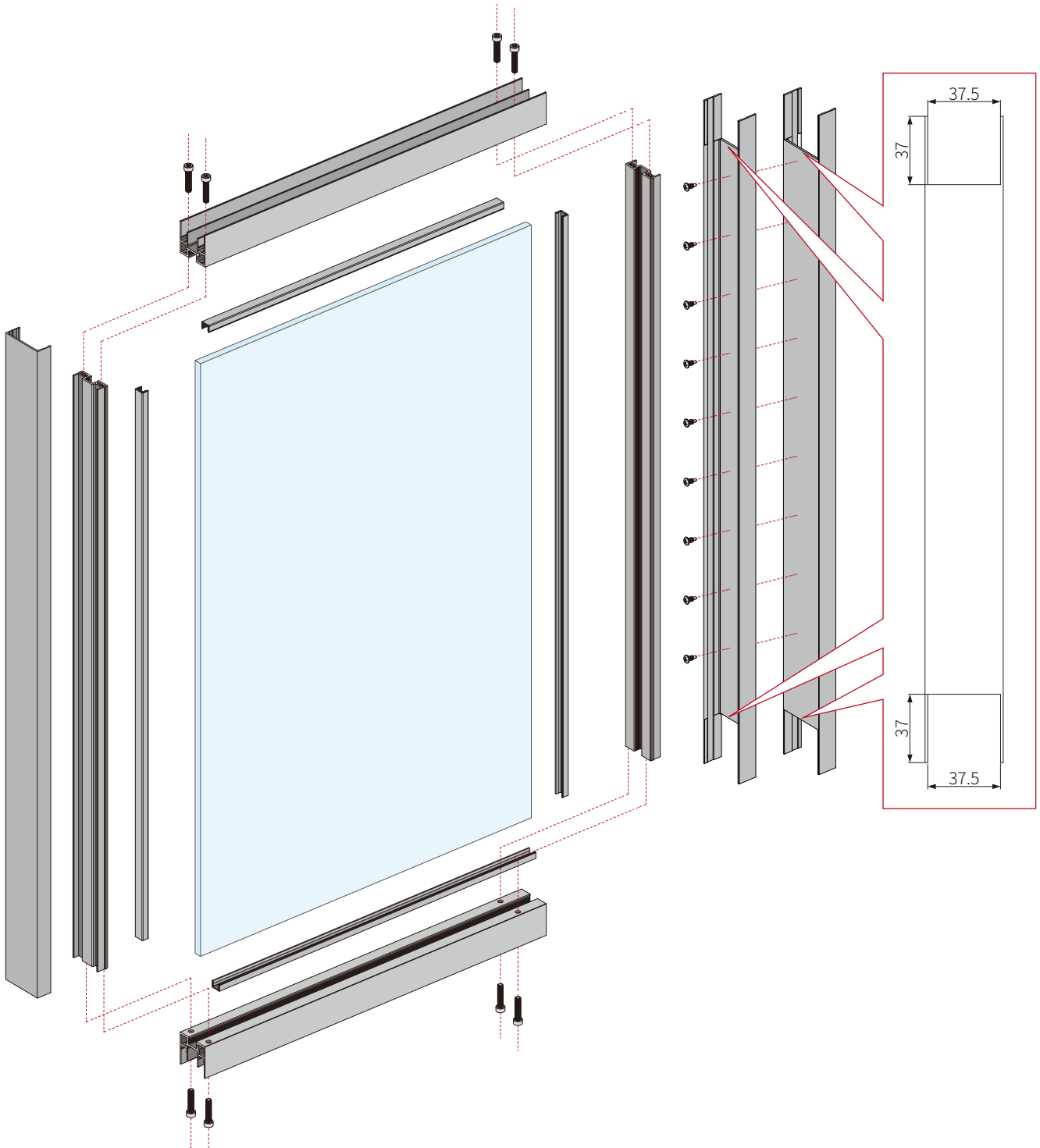

## 3-2 Install the Door FD

⚠ Please refer to the door panel production manual for detailed installation

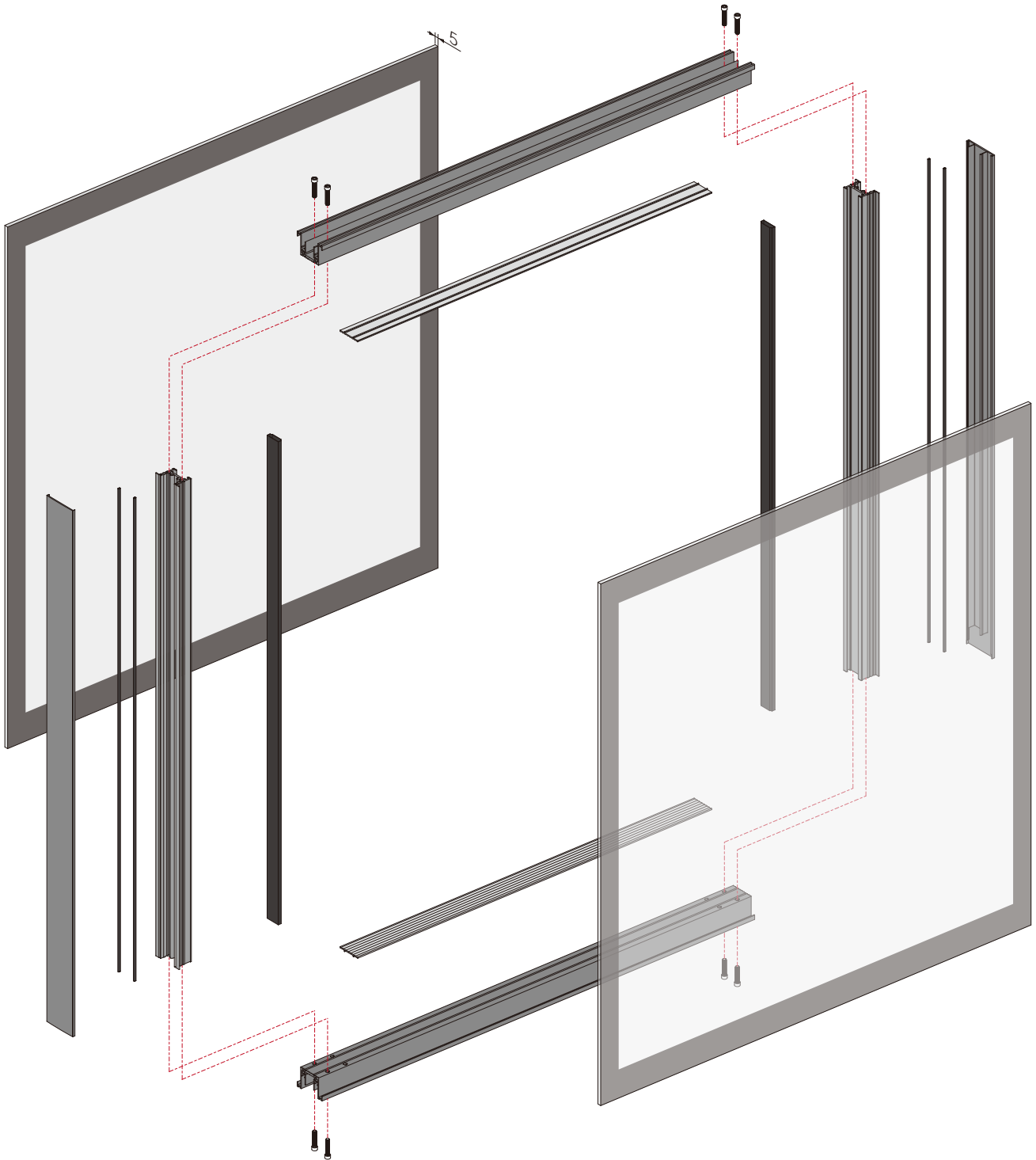

### 3-3 Install the Door FW

 Please refer to the door panel production manual for detailed installation

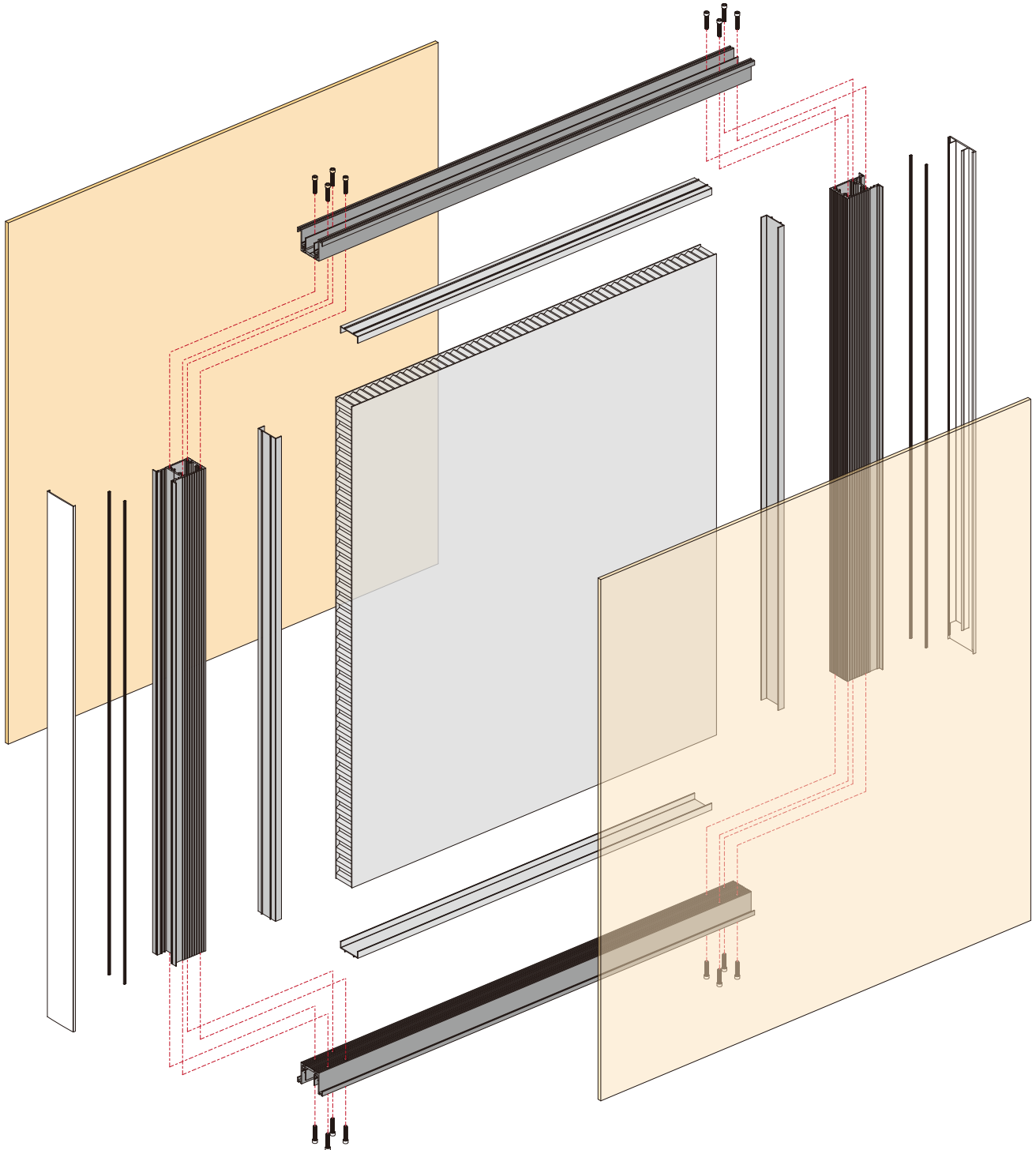

### 3-4 Install the Door W

 Please refer to the door panel production manual for detailed installation

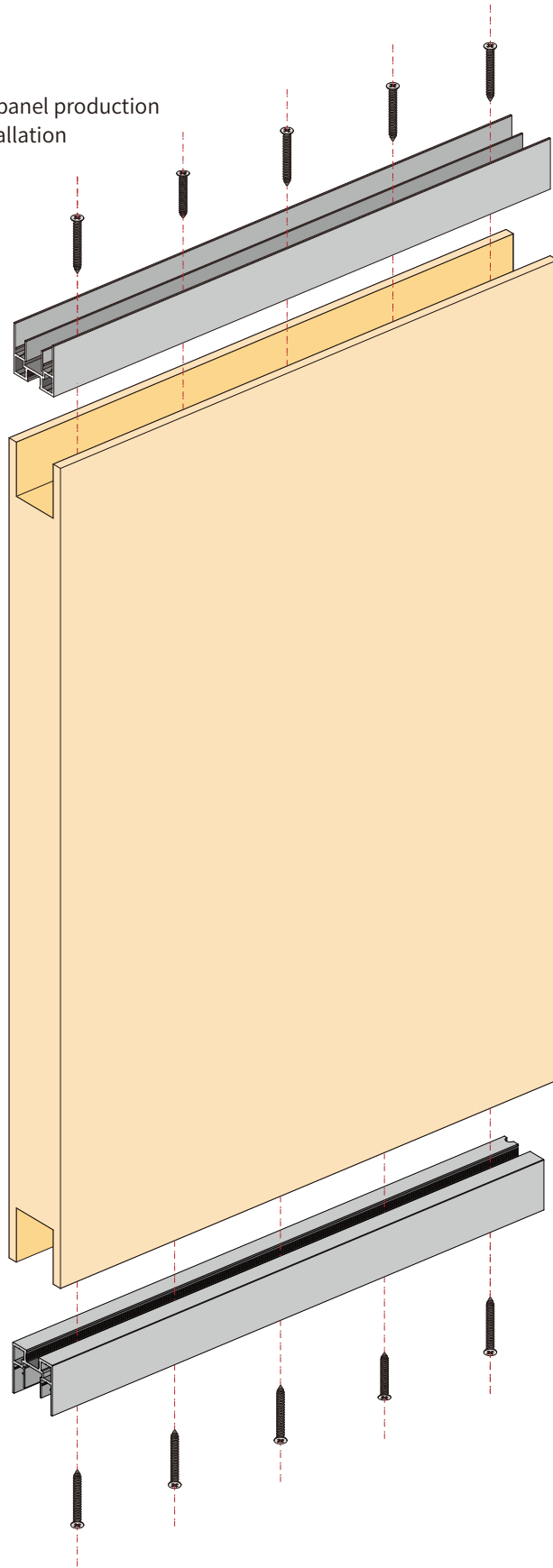

**5** Cut the Profiles    Disassemble the Profiles

**!** Cutting from the uneven side of the profiles

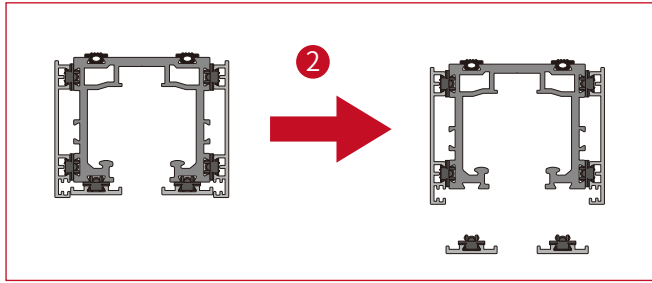
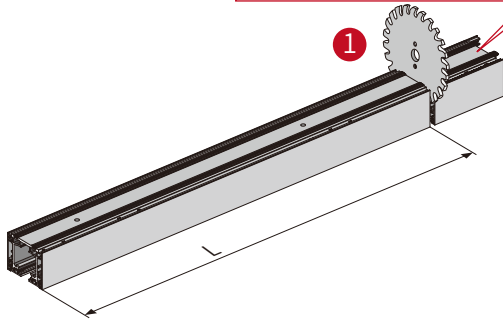

**6** Install Rollers and Activators

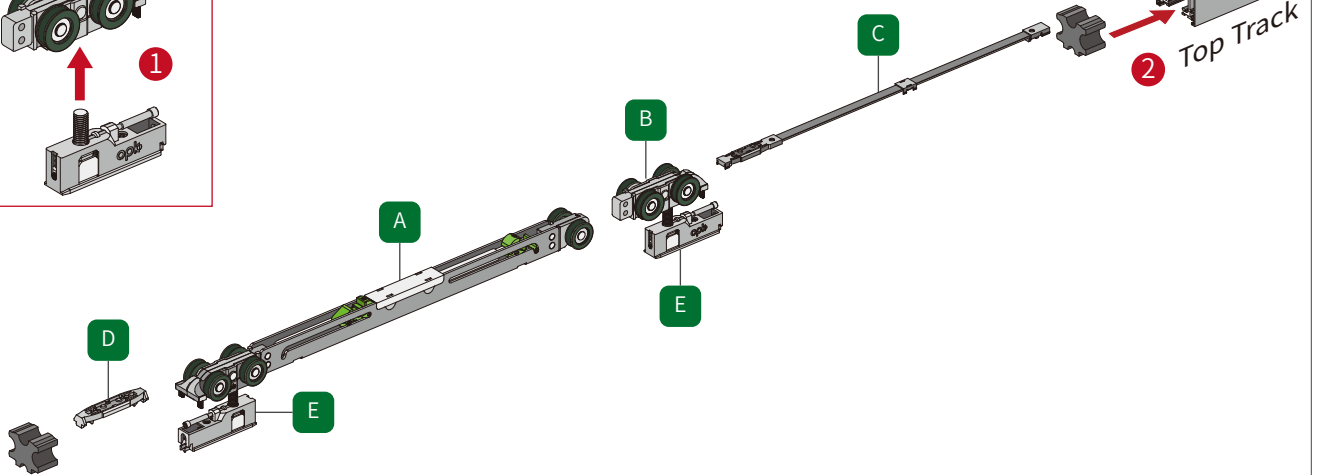
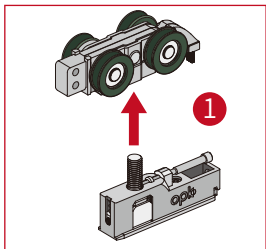

**7** Install the Long Activator

Note: plastic inside a head towards the track

Insert stopper from right side of track end cap

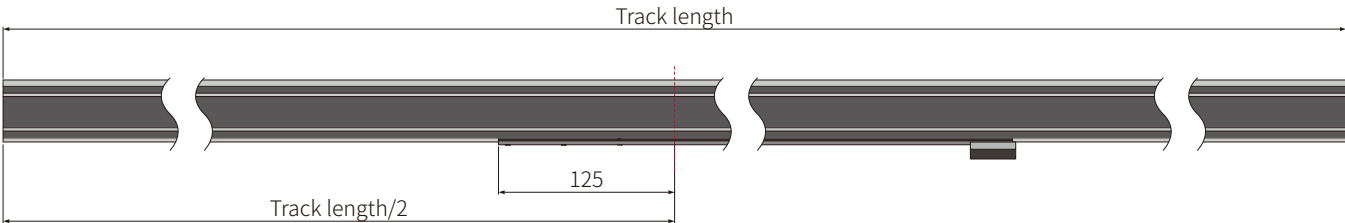
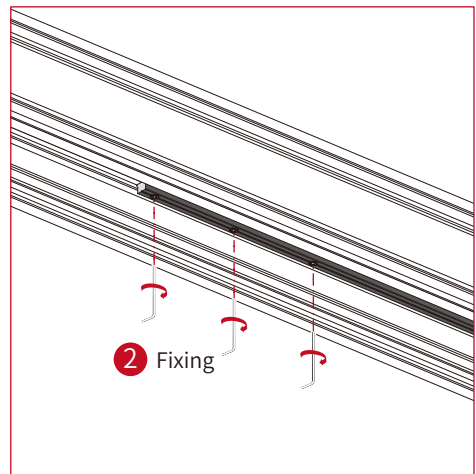
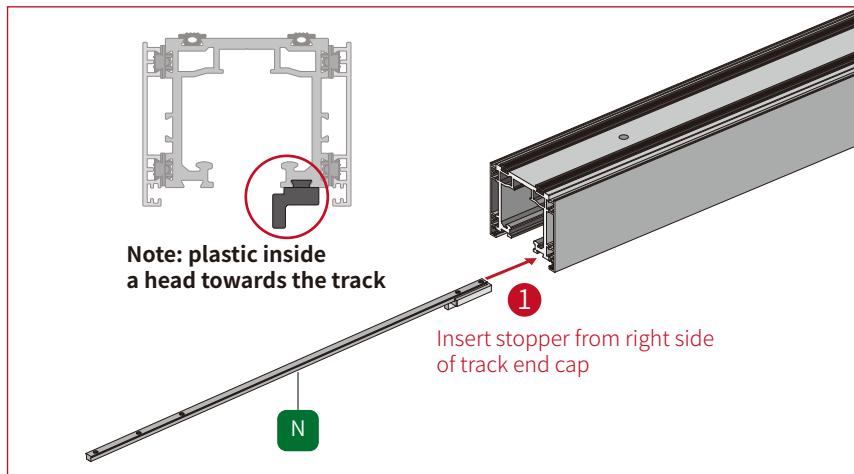

## 8-1 Install Track Accessories

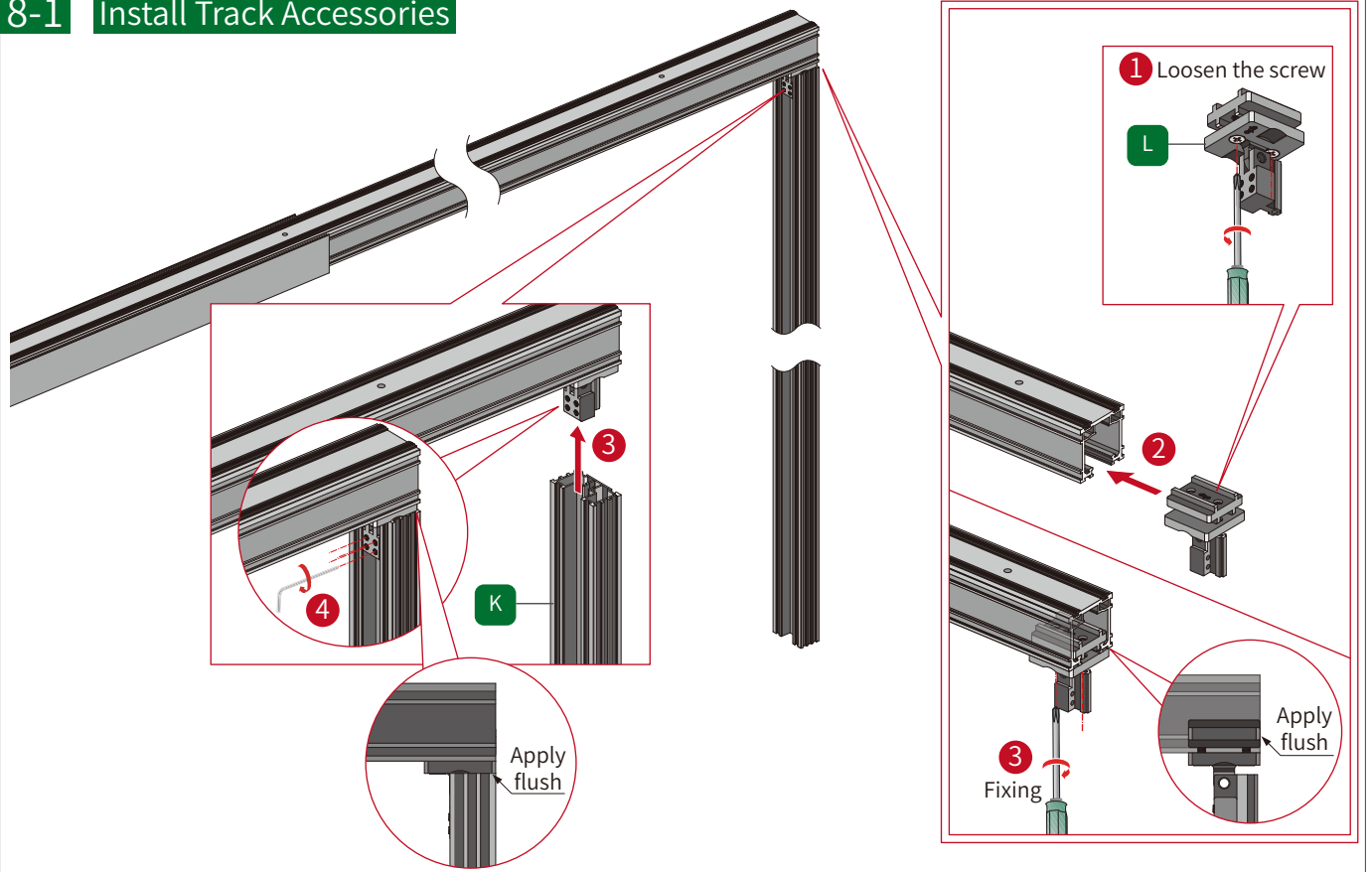

## 8-2 Install Track Accessories

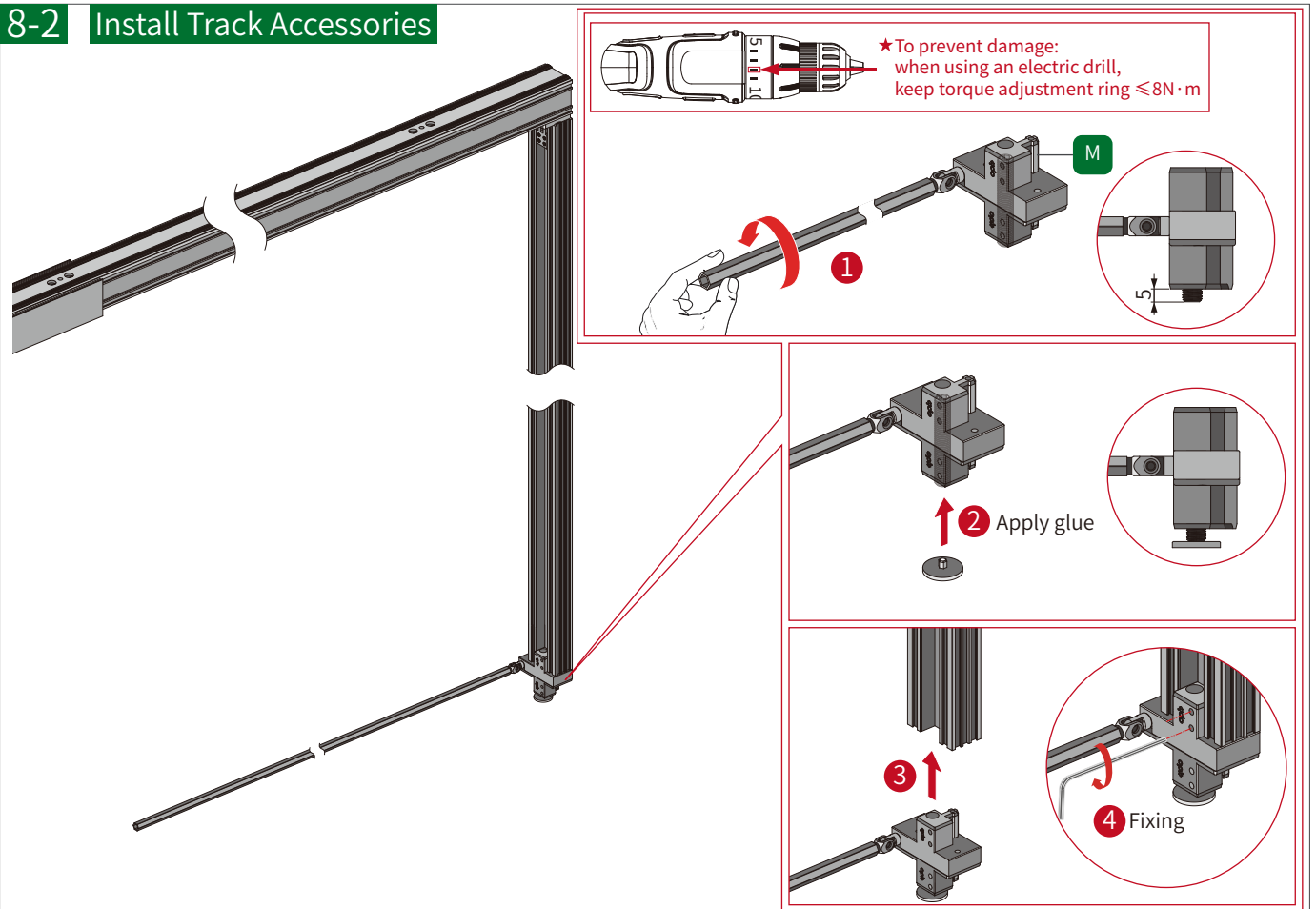

## 9-1 Install the track

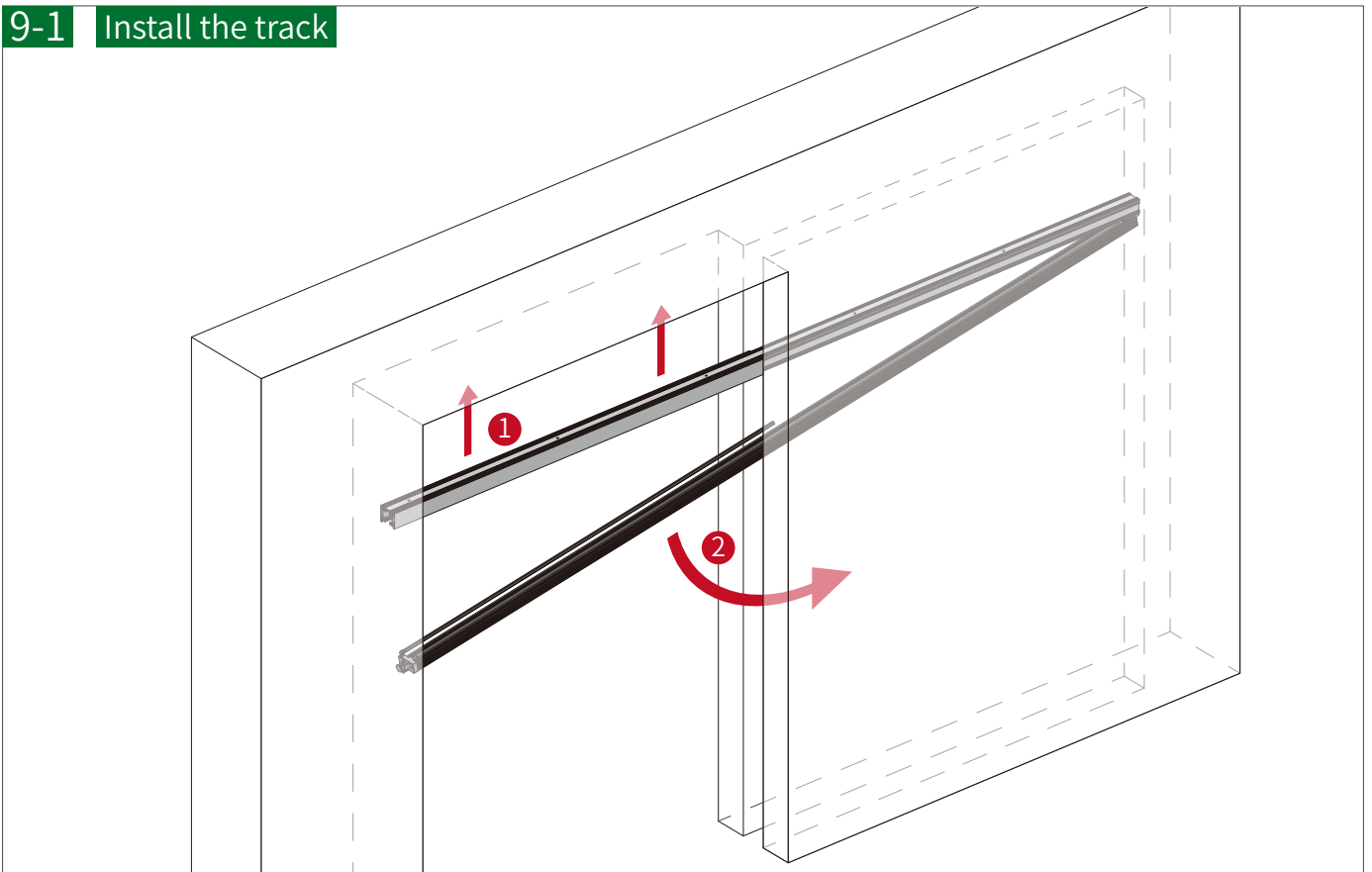

## 9-2 Install the track

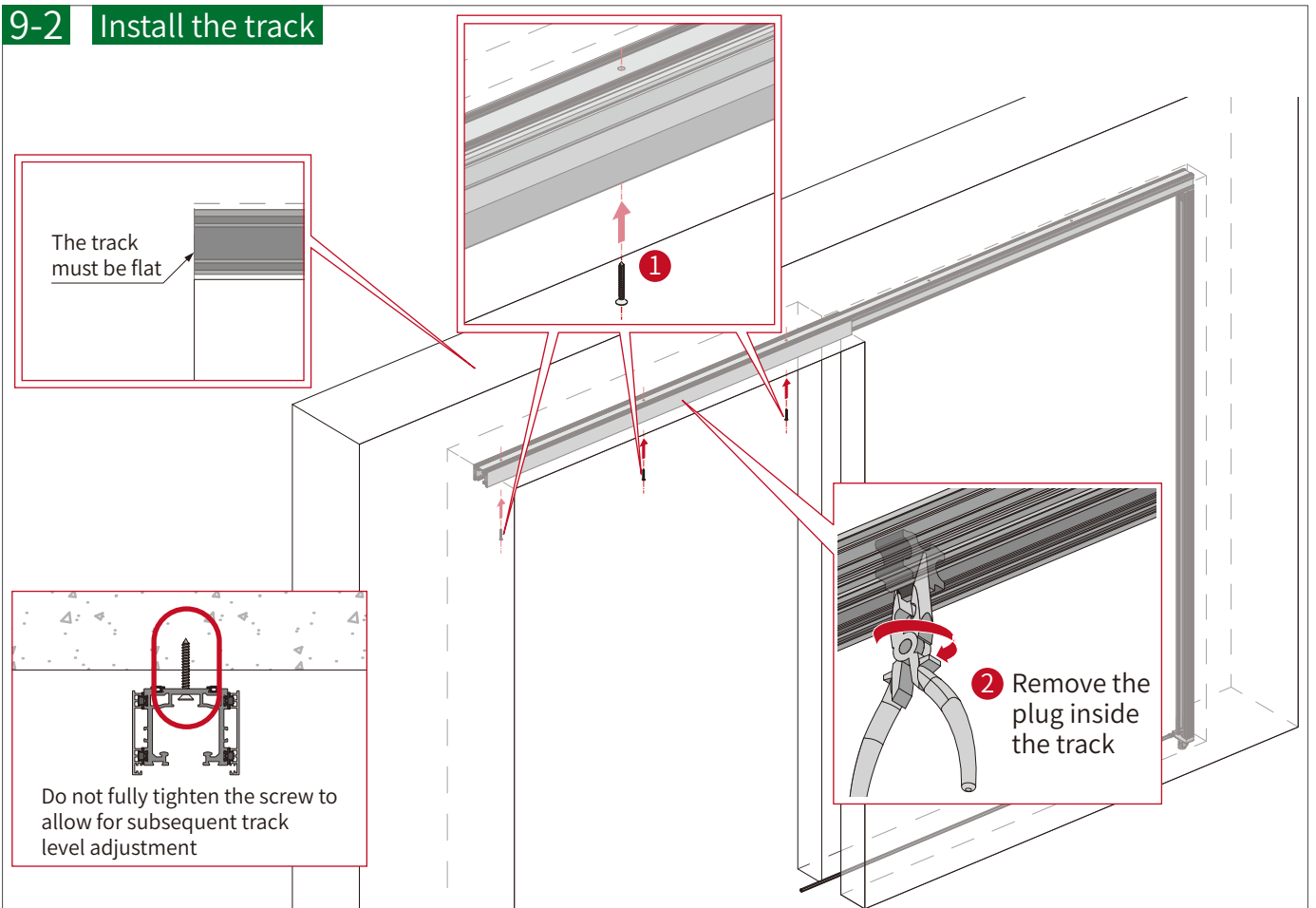

### 9-3 Install the track

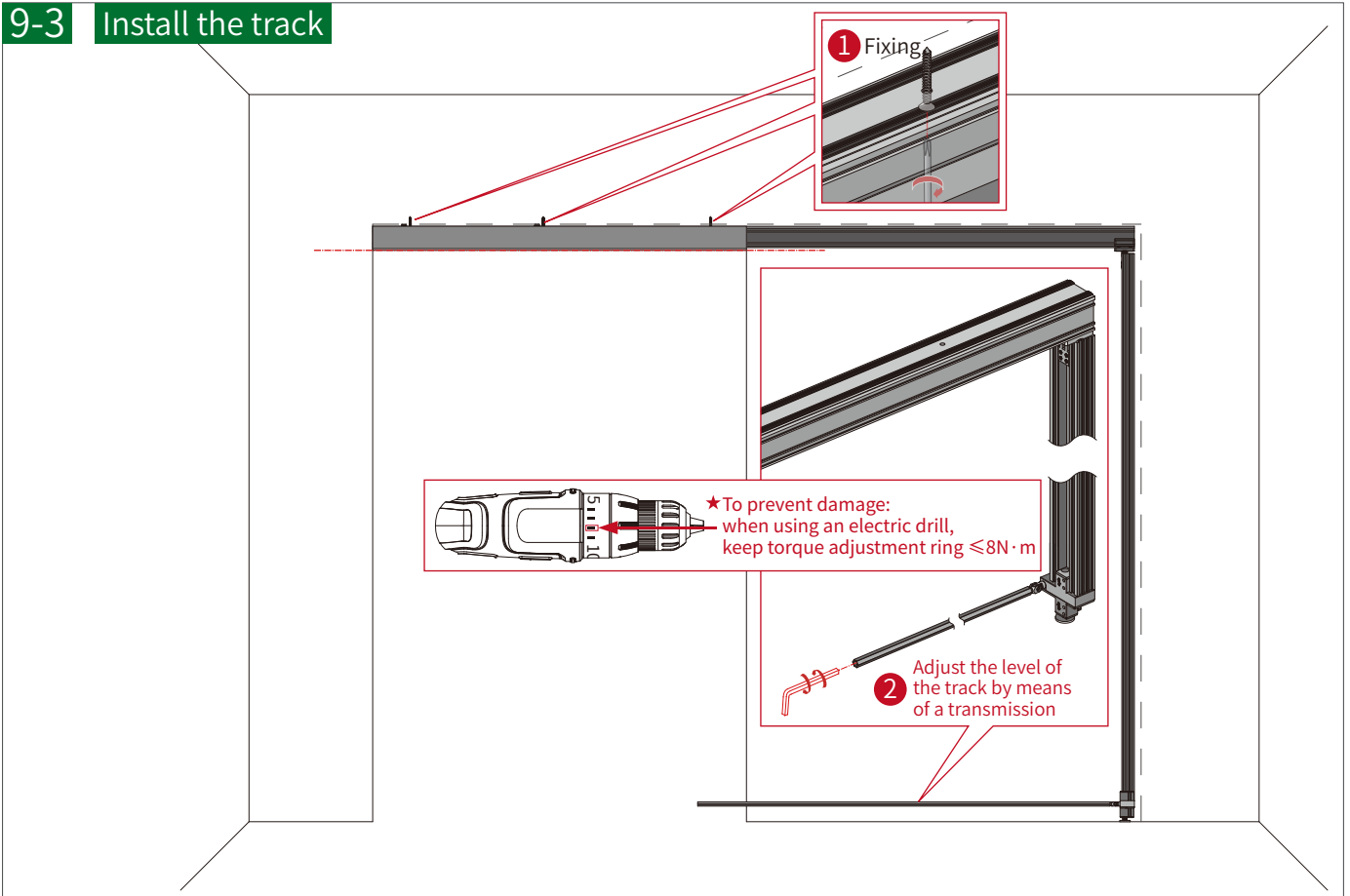

### 10 Install the extended stopper

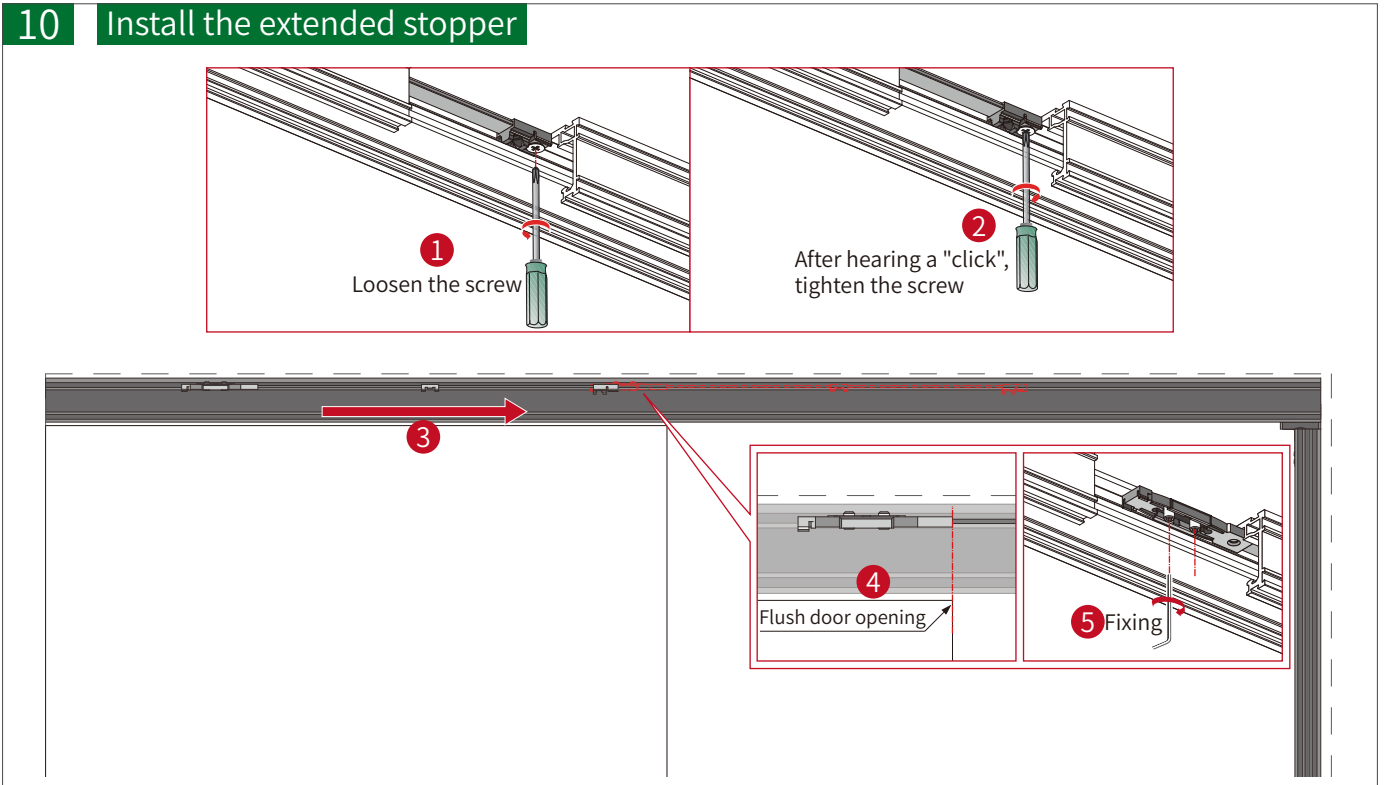

## 11 Install the Support Bracket Place the Pocket Door Adjustment Rod

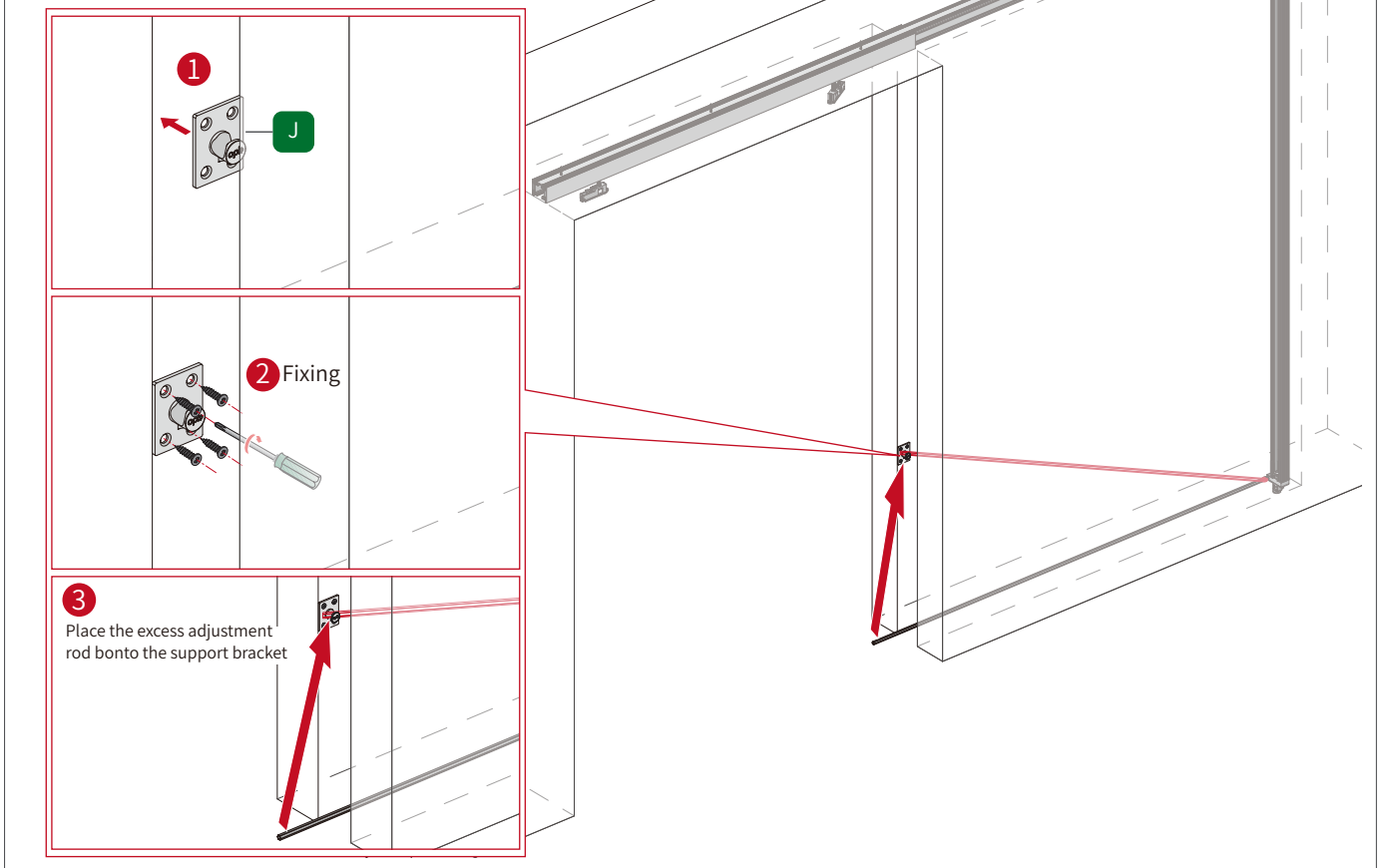

## 12 Install the Bottom Stopper

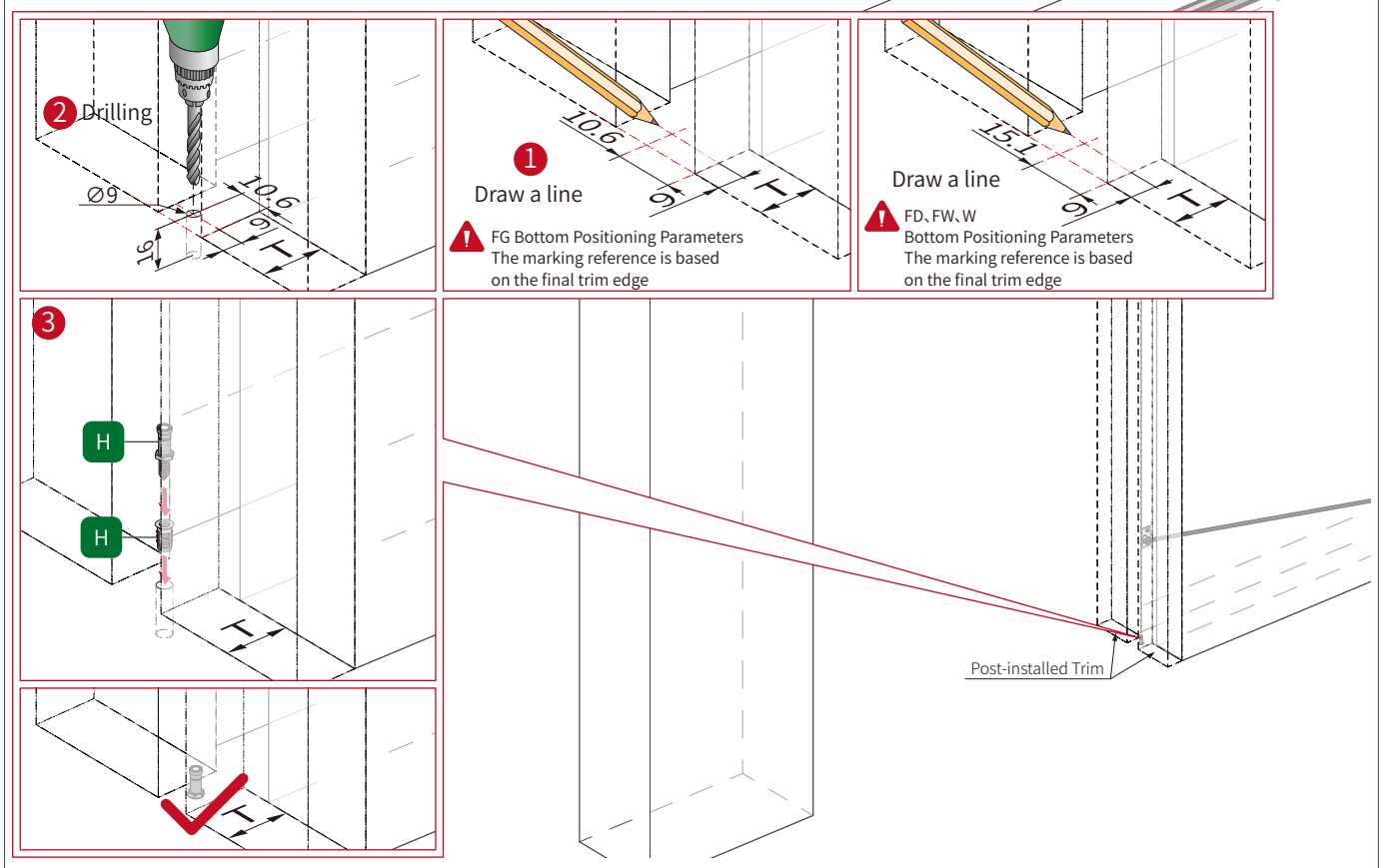

### 13-1 Install the Door Panel

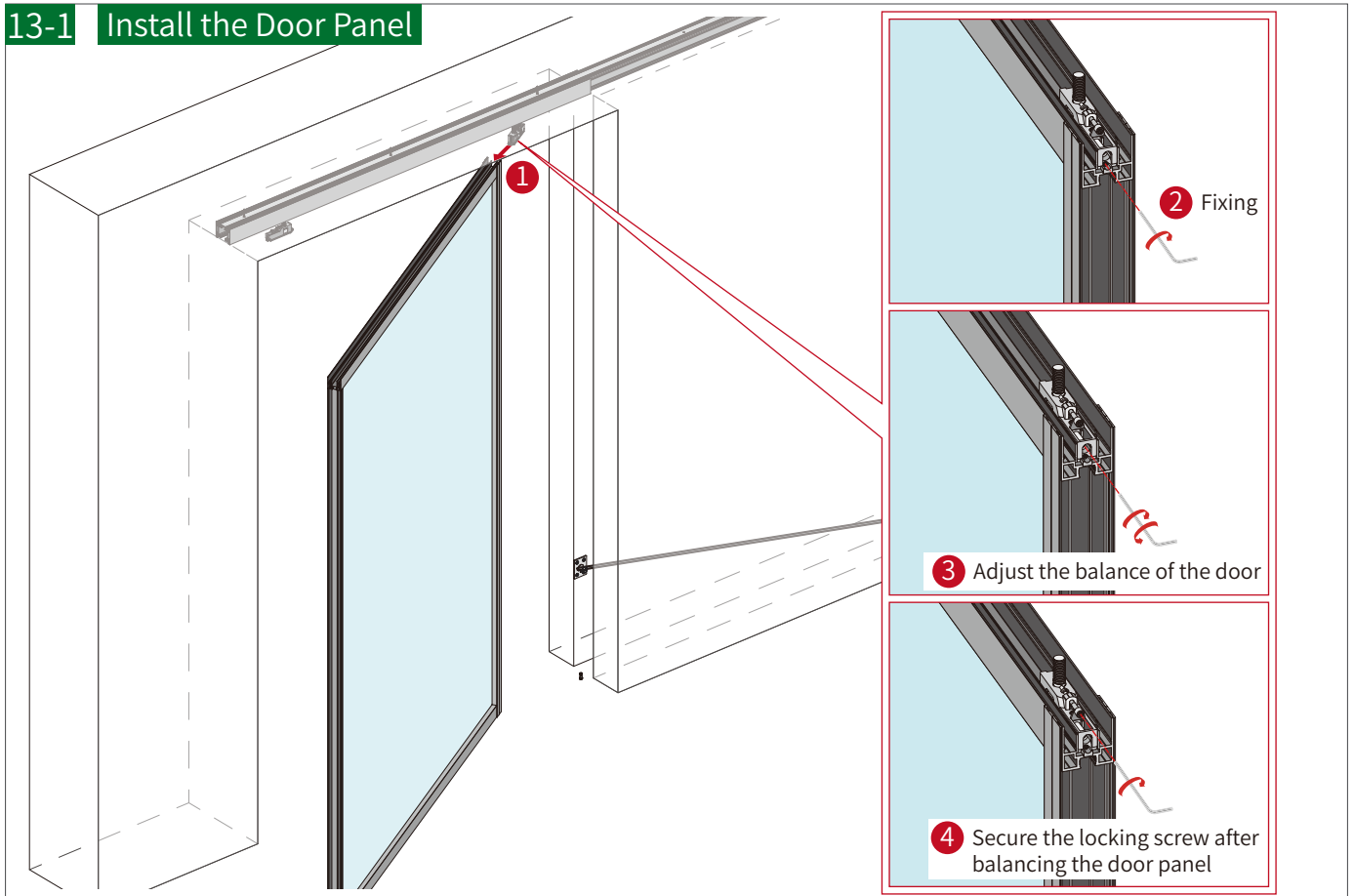

### 13-2 Install the Door Panel

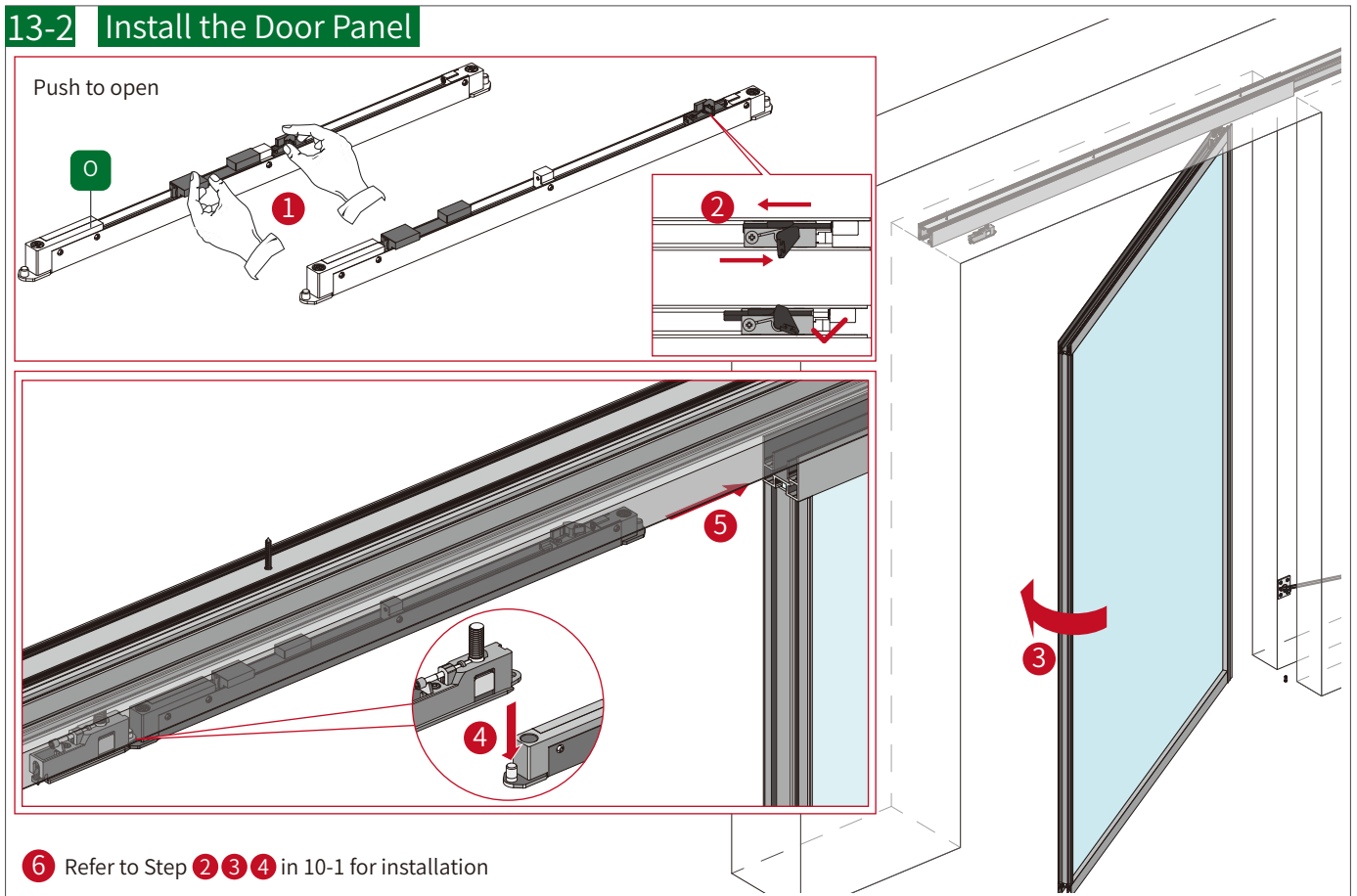

## 14 Install the Bottom Roller    Install the Anti-Push Bracket

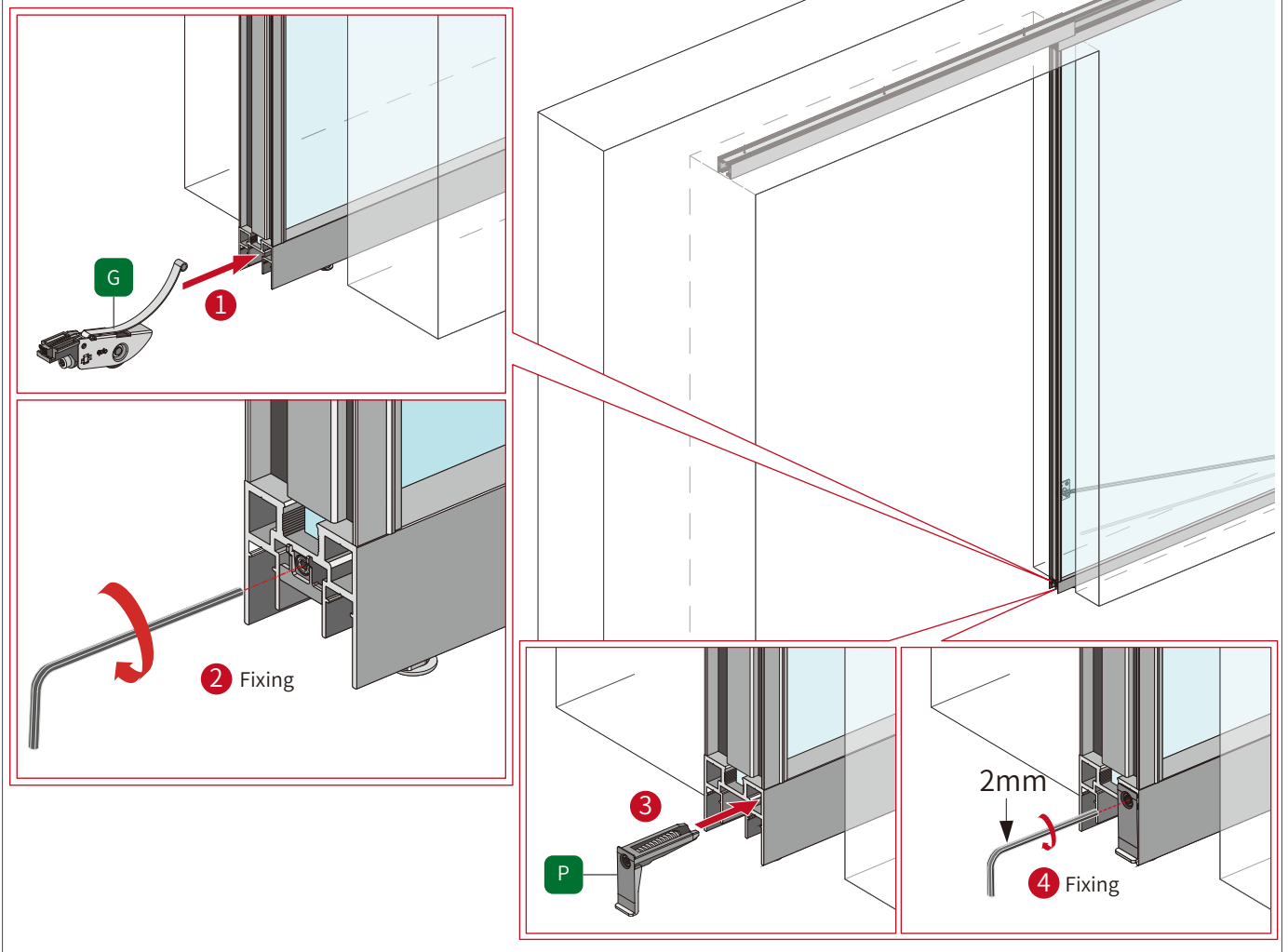

## 15 Install the Door Vertical Frame

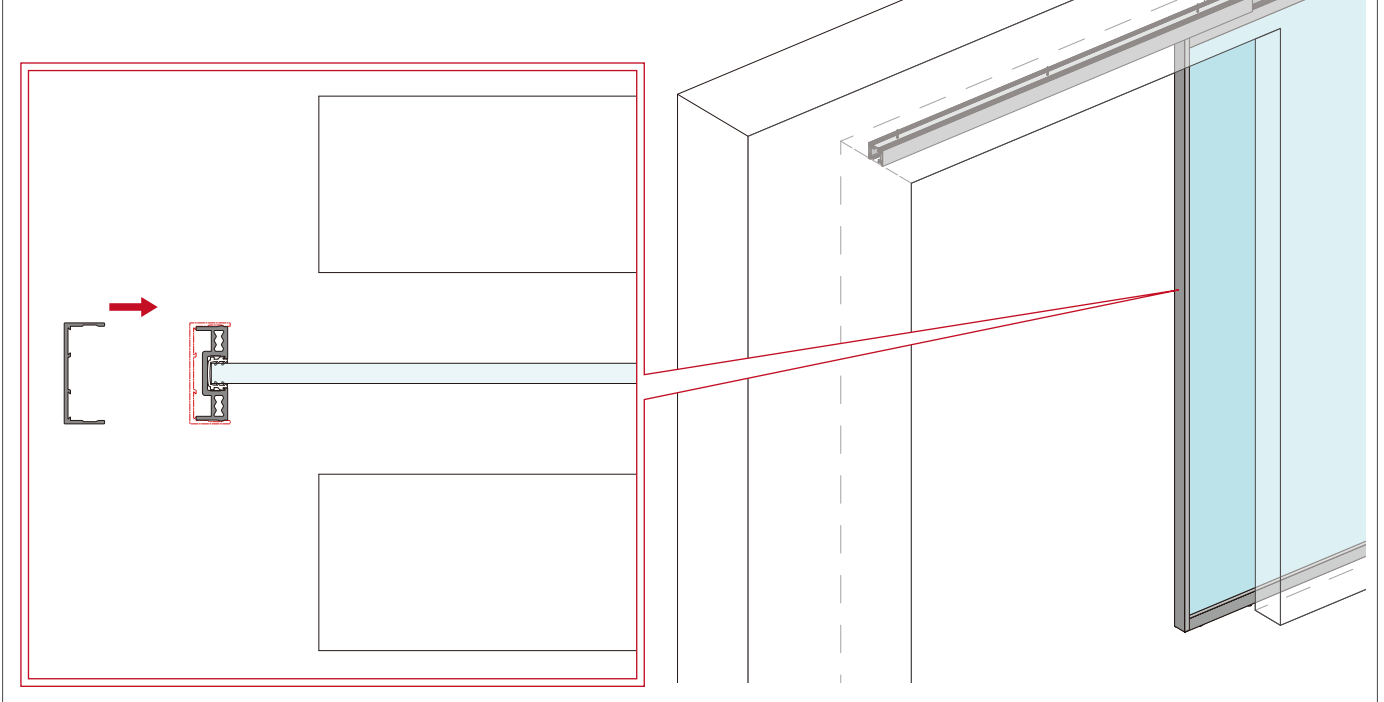

## 16 Locate the Stopper

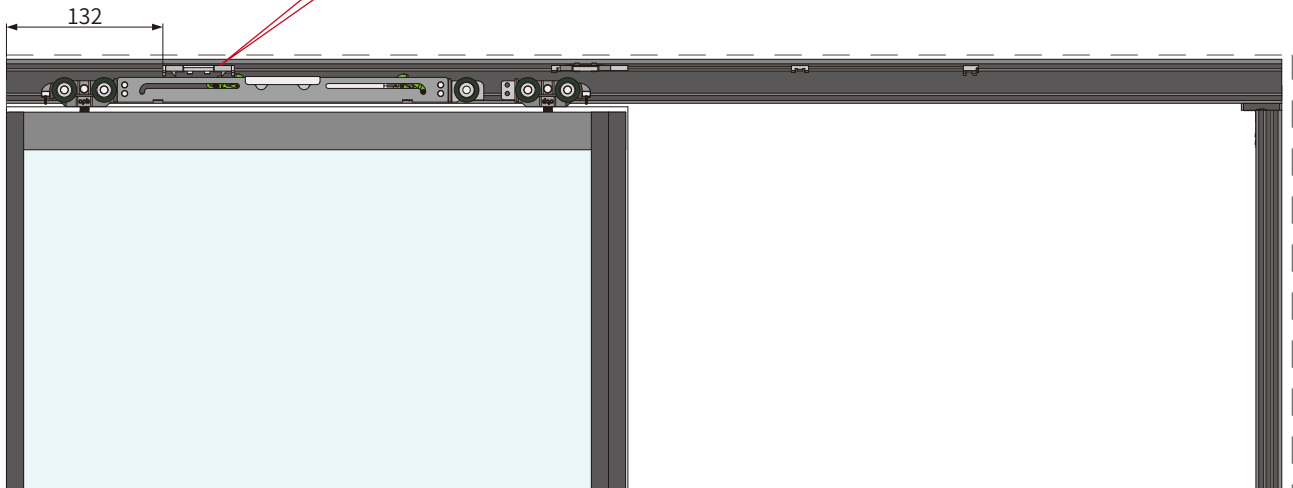
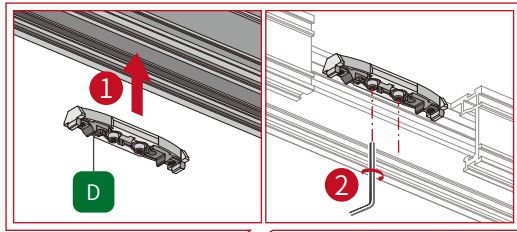

## 17 Install the Extended Stopper

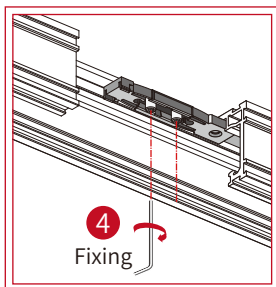
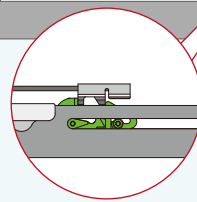
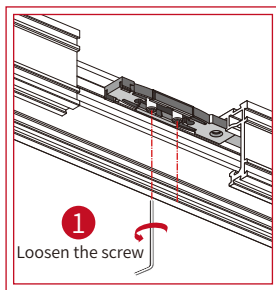

3  
Door panel from the  
door opening was 7 mm

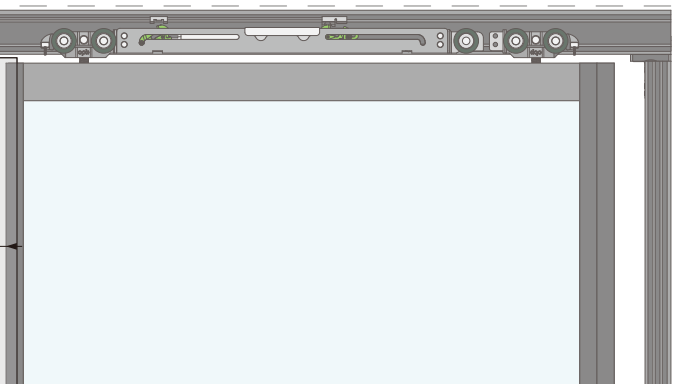

## 18 Locate the Limit Part of the Stopper

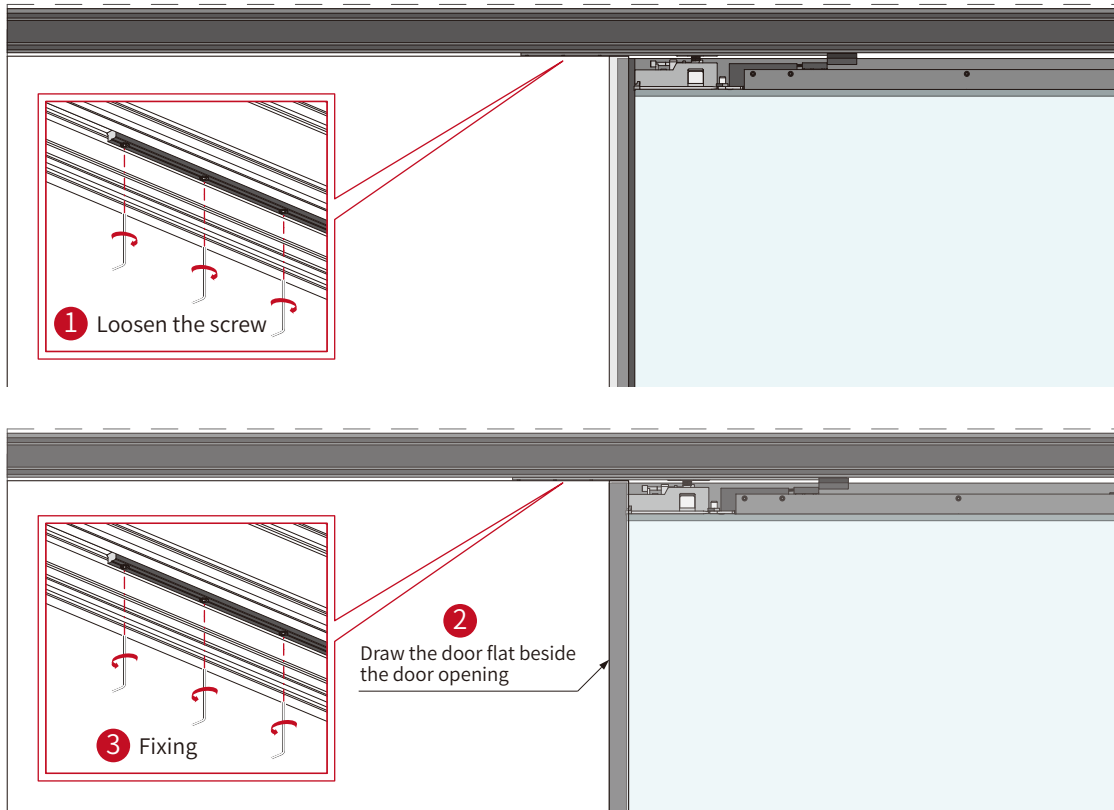

## 19 Install the Cover Install the trim

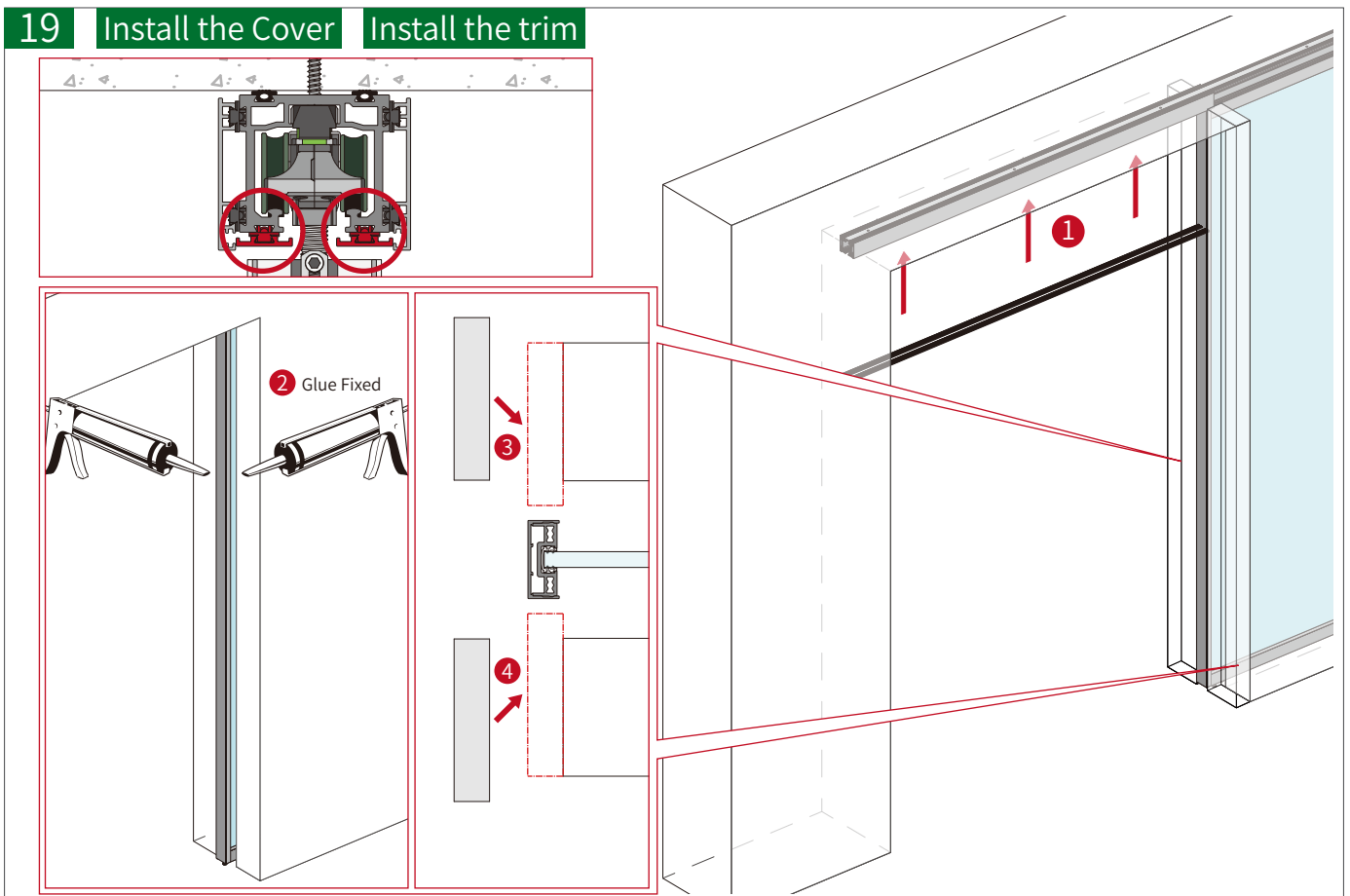

## 20 Install the Cover

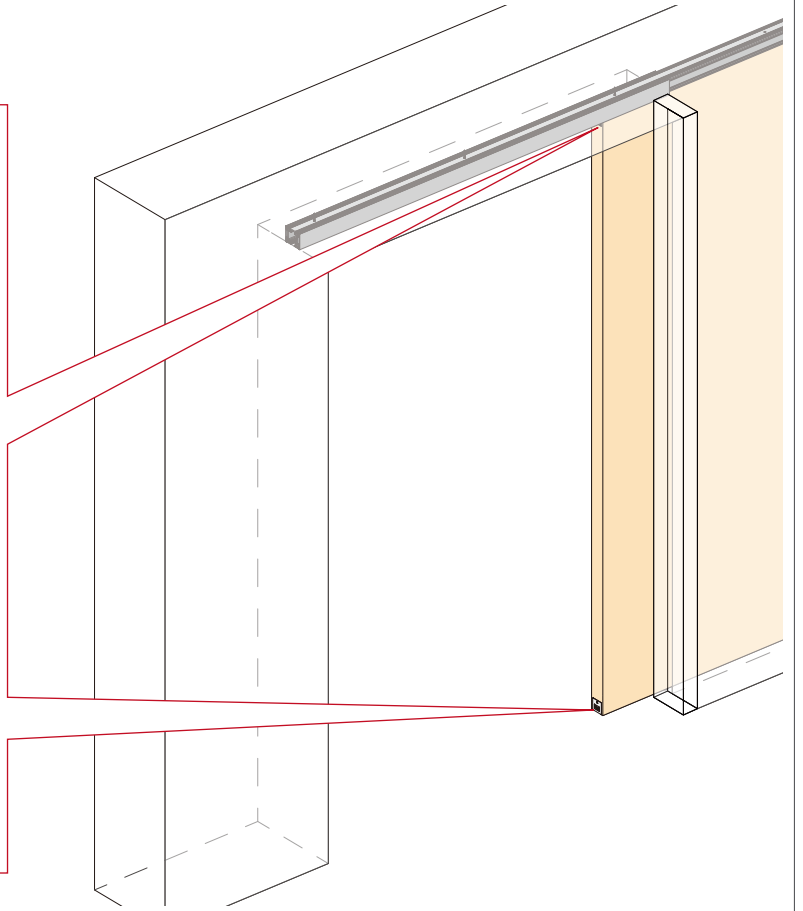
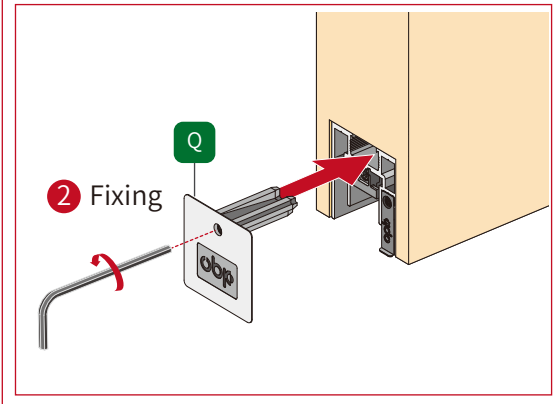
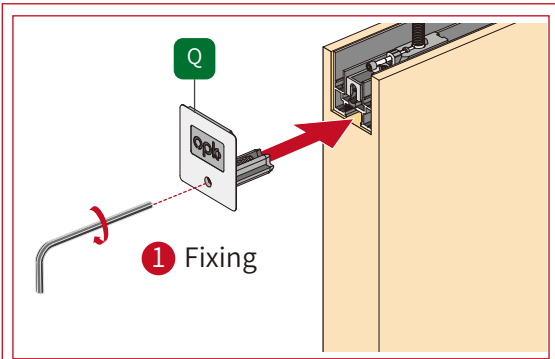

# Maintenance & Replacing

## 1 Disassembly of the Damper

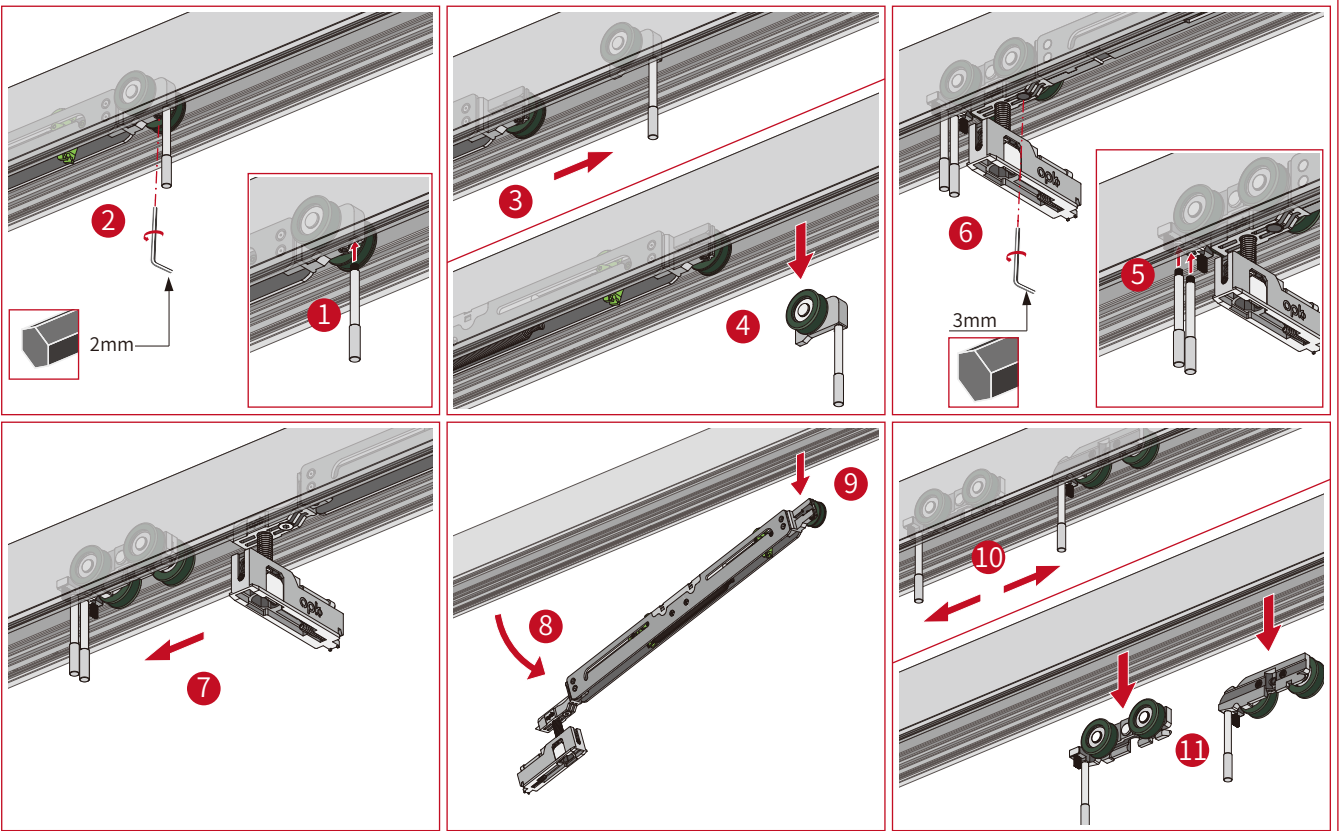
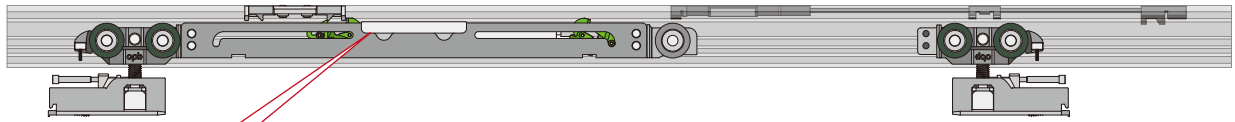

# Maintenance & Replacing

## 2 Disassemble the Top Roller

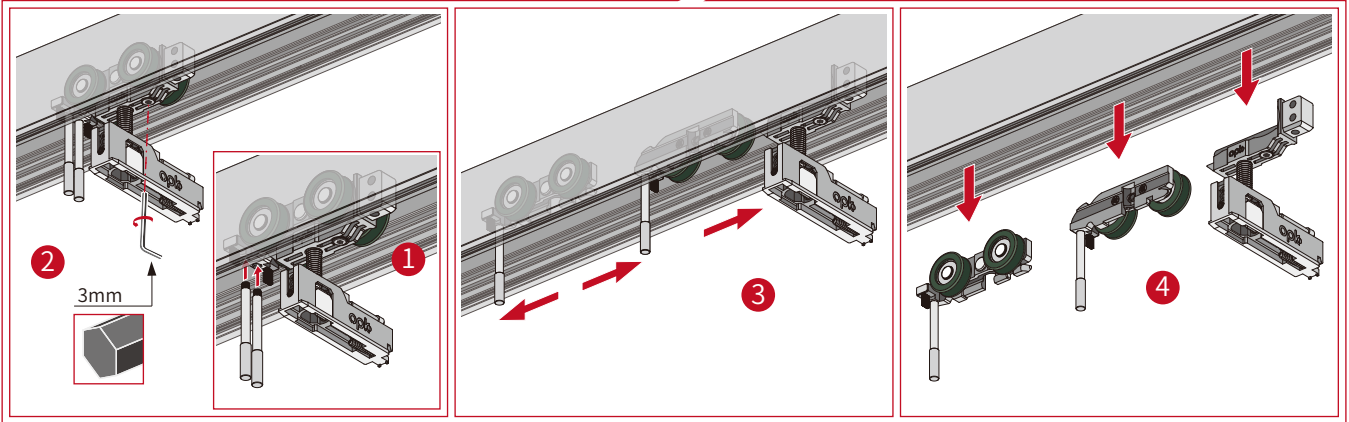
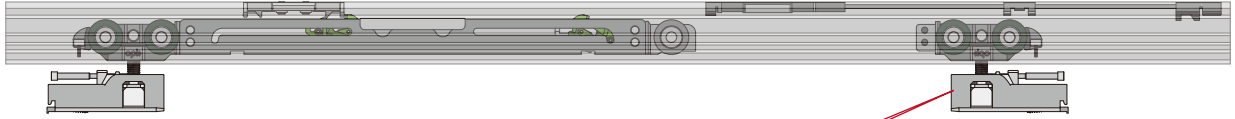

## 3 Disassemble the Extension Limiter

